

INSTRUCTION MANUAL
FOR
BROTHER MODEL EF4-B956C



Ultra High Speed Overlock Sewing Machine

BROTHER INDUSTRIES, LTD.
NAGOYA, JAPAN

CONTENTS

| | |
|---|----|
| 1. Specifications | 1 |
| 2. Features | 2 |
| 3. Operation | 2 |
| A) Sewing speed | 2 |
| B) Motor, motor pulley and belt | 2 |
| C) Setting up | 3 |
| D) Oiling, draining and maintenance | 3 |
| E) Needle cooler device | 4 |
| F) Machine operating direction | 5 |
| G) Installing needle | 5 |
| H) Threading | 6 |
| I) Stitches | 6 |
| J) Thread tension | 7 |
| 1. Adjustment of thread take-up | 7 |
| 2. Adjusting thread take-up and thread guide | 7 |
| 3. Adjusting thread tension screw | 7 |
| K) Adjustment on pressure of presser foot: Installing and removing feed dogs: and Height of feed dogs | 8 |
| L) Adjusting stitch width | 8 |
| M) Adjusting stitch length | 9 |
| N) Adjusting differential feed | 9 |
| 4. Adjustment | 10 |
| A) Height of needle | 10 |
| B) Relation between needle and under looper | 10 |
| C) Installing needle guard rear | 10 |
| D) Installing needle guard front | 11 |
| E) Relation of needle with under and over looper | 11 |
| F) Installing and maintenance of knives | 11 |
| 5. Trouble shooting | 12 |
| A) Thread break | 12 |
| B) Skip stitching | 12 |
| C) Needle break | 12 |
| D) Imperfect chaining-off | 13 |
| E) Improper thread tension | 13 |
| F) Poor trimming performance | 13 |
| G) Irregular stitches | 13 |
| H) Excessive wrinkles along stitches | 14 |
| I) Needle produces too large holes | 14 |
| 6. Parts list | 15 |

1. Specifications

| | |
|-----------------------------|---|
| Name | Ultra High Speed Overlock Sewing Machine |
| Dimensions | 355mm × 240mm × 270mm |
| Type | Dust-proof, totally enclosed type |
| Stitch from | E13, E13A, E12A |
| Sewing speed | 6,500 stitches per minute |
| Stitch length | 1mm~3.6mm (for sub-class -01 & -09) 1mm~5mm (for sub-class -11) |
| Stitch width | 3~5mm by changing the needle plate |
| Height of presser foot | 5mm |
| Main bearings and rods | All important parts are of phosphor bronze alloy also oilless metal and ball bearings |
| Oil | Viscosity: CS 20.62 at 37.8°C Capacity: 800~1,000cc. |
| Needle bar stroke | 24mm |
| Needle | DC × 1 (#7, #9, #11, #14, #16) |
| Feed regulator | Push-button type, scale on face plate represents stitch length |
| Differential feed regulator | By lever moving in vertical direction; gathering and stretching can be obtained even in sewing operation. |
| Knives | Upper knife: L-shaped carbide tipped Lower knife: flat shaped steel |
| Installation | Semi-submerged |

Of this machine, there are the following sub-classes available.

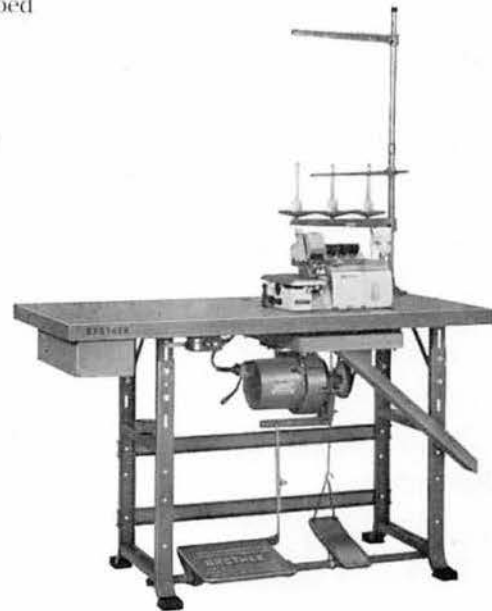

| Type | Overedging | Blind-hemming | Serging |
|--|------------|---------------|----------|
| Sub-class | -01C | -09C | -11C |
| Maximum sewing speed | 6,500spm | 6,500spm | 5,500spm |
| Needle cooler | Equipped | Equipped | Equipped |
| No. of needle | 1 | 1 | 1 |
| No. of threads | 3 | 3 | 2 |
| Sewing width (Bight) | 3, 4, 5mm | 3, 4mm | 5mm |
| Needle | DC×1 | DC×1 | DC×1 |
| Height of presser foot | 5mm | 5mm | 3mm |
| Stitch length | 1mm~3.6mm | 1mm~3.6mm | 1mm~5mm |
| Differential feed ratio (gathering-stretching) | 1.5~0.7 | 1.5~0.7 | 1.2~0.7 |

2. Features

- * The extensive design of various components and lubrication system and also the addition of the needle cooler device on this machine assure the normal operation of maximum high speed of 6,500 stitches per minute, without any troubles.
 - A) Combined lubrication system of forced lubrication by geared pump, splash lubrication and oil wick lubrication.
 - B) Unique design of needle bar mechanism has lessend its weight as well as assures forced lubrication to its every working part.
 - C) Exclusively designed over looper mechanism has made the use of light alloy possible and also ensures smooth lubrication to the end.
 - D) Holders are made of duralmin to decrease the weight. Main rods and bushings are made of phospher bronze alloy.
 - E) Major moving parts are perfectly lubricated inside the totally enclosed main body, so they will never be exposed to outside dusts.
- * The upper knife is L-shaped to make the threading and replacement of the needle easy. Besides, the carbide tip promises long durability of the knife.
- * Stitch can be easily regulated by push-button, with the scale on the face plate, thus it is unnecessary to change the eccentrics when you would like to change the stitch length.
- * Differential feed can be easily adjusted by the lever for gathering or stretching without soiling your hands. This also applies for the instantaneous differential adjustment obtainable.
- * Ample space on the cloth plate allows easy sewing operation.
- * Oil level in the oil reservoir is shown on the special oil gauge on the front side of the machine.
- * Lubrication can be easily checked through the oil window in the top cover.
- * Optional needle cooler ensures perfect sewing operation even with synthetic materials and threads at the high speed of 6,500 stitches per minute.
- * Colour combination of TAN-BEIGE is in well harmony with your modern factory, and operator's fatigue can be lessened.
- * As differential ratio can be adjusted upto 2.5, this is suitable for sewing of cloth which is ease to spread such as knitted fabric.

3. Operation

A. Sewing speed

Maximum speed of this machine is 6,500 stitches per minute. For the first 100 actual working hours, however, the new machine should be operated at about 5,000 s.p.m. so that all the working parts are well run-in. After this running-in period, you may operate the machine at maximum of 6,500 stitches per minute. This is desirable for machine's long life.

B. Motor, motor pulley and belt.

- 1) Use a clutch motor, 1/2 Hp, 2 pole, single or three phase. Our motor available is Models MD-344 (single phase) and MD-354 (three phase).
- 2) Use M-type V-belt.
- 3) Machine speed (s.p.m.), diameter of motor pulley and length of motor belt is related to the following table.

| Stitches per minute | Outside diameter of pulley and length of V-belt | | | |
|---------------------|---|---------|--------|---------|
| | 50 Hz | | 60 Hz | |
| | Pulley | V-belt | Pulley | V-belt |
| 5,500 | 120mm | 39 inch | 100mm | 38 inch |
| 6,000 | 130mm | 39 inch | 110mm | 38 inch |
| 6,500 | 140mm | 39 inch | 120mm | 38 inch |

C. Setting up

This machine is normally set up as semi-submerged type. Necessary parts and accessories for setting up this machine are contained together with the machine head.

If you have purchased this machine as head only, make table top as per attached table sheet, also refer to Fig. 1, which shows the parts necessary for setting up this machine and also the measurement to mount the bottom board to the table as semi-submerged type.

With our Brother clutch motor, Models MD-344 and MD-354, there is no anxiety to set the machine to the bottom board, however, if you would use with other brand clutch motor, please make sure to have proper holes on the bottom board.

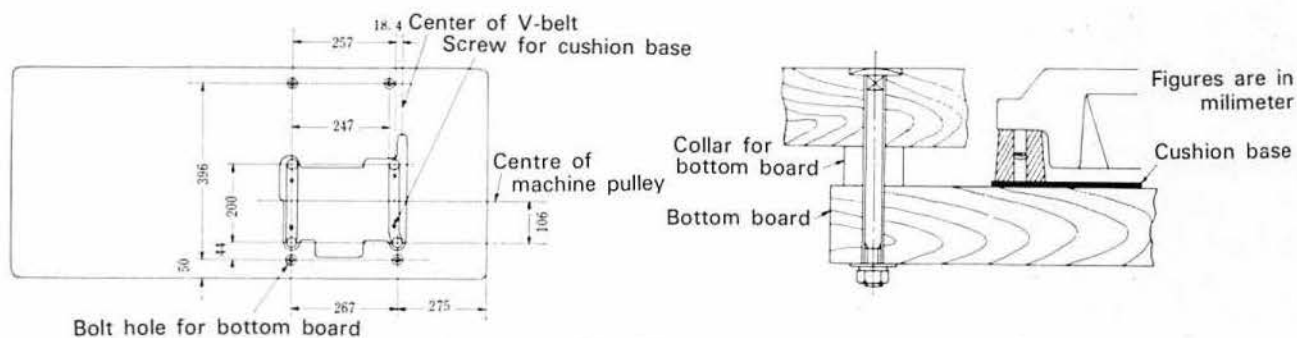

(Fig. 1)

D. Oiling, draining and maintenance



(Fig. 2)

Oil is drawn out of the machine prior to its shipment.

Before operating the machine, therefore, remove the oil filter cap (shown in Fig. 2) and pour oil into the machine using the funnel.

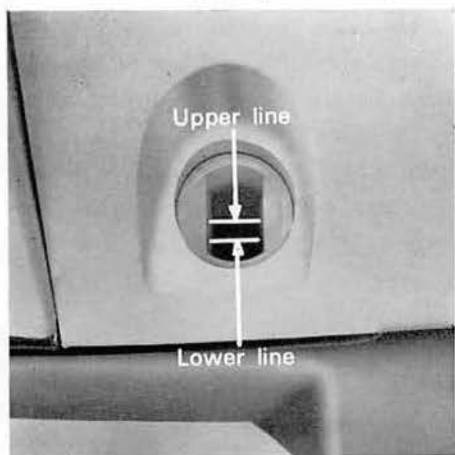

(Fig. 3)

Oil level should be up to the upper line of the oil gauge shown in Fig. 3.

The oil reservoir consists of two tanks partitioned by a filter so it takes sometime before the oil levels of both tank match. Check if oil is up to the required level a little after the oil is poured. Add oil if oil level is below the upper line of the oil gauge. Be sure to check the oil gauge for oil level before operating the machine.

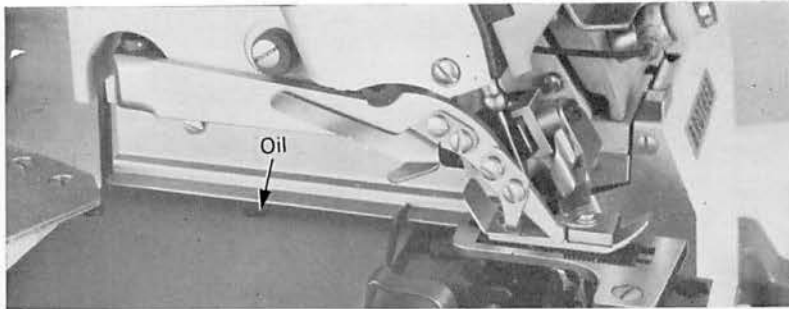

(Fig. 4)

When operating the machine for the first time after unpacking it or after it has been out of oil for a long period of time, add 5 or 6 drops of oil into oiling point shown in Fig. 4 and Fig. 5. You do not have to add oil into them if the machine is operated daily.

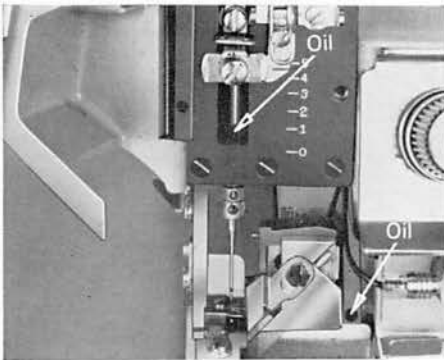

(Fig. 5)

At the end of 100 actual hours operation, running-in period, change the oil.

Thereafter, change it once in about three months use. The quantity of oil required is about 800-1,000cc. Remove the screw shown in Fig.6 for draining oil.

The machine employs a geared pump for the forced lubrication to its major moving parts. It is recommended that the oil reservoir be dismounted about twice a year for cleaning of its inner surfaces, pump, wire gauze, etc.

This is desirable for long life of the machine.

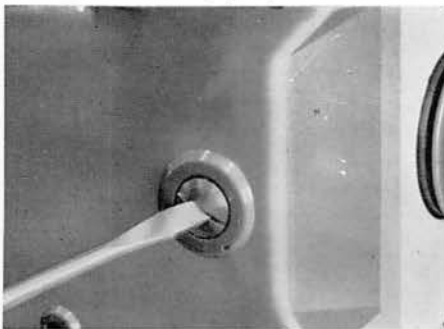

(Fig. 6)

E. Needle cooler device

With machine model "C", it is equipped with the needle cooler device.

In order to get the good sewing result on the resin treated materials such as polyester, jersey, and tricot, etc., or with the synthetic threads, such as nylon and Dacron, it will be advantageous to use the needle cooler device.

1. Operating procedure

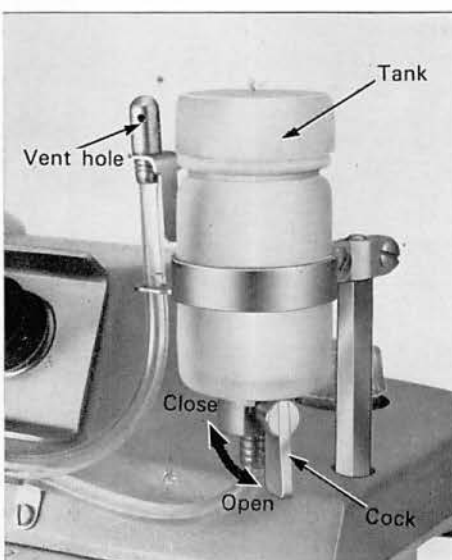

- 1) Pour the silicone oil into the tank approximately 4/5 in capacity (50cc in capacity) then open the cock shown in Fig. 7.
- 2) If this machine is brand new or after it has been out of use for long time, it takes about 10-15 minutes to saturate the silicone oil into the felt on the needle guard, then apply several drips of silicone oil on the felt so as to thoroughly saturate before sewing operation.
- 3) The cock must be closed when the machine do not require the silicone oil, namely on the slow speed operation on cotton thread, cotton materials applied and also when you do not use the machine.

(Fig. 7)

2. Sewing capability with needle cooler

When you would sew the synthetic materials, jersey, tricot, etc., it can be ensured to sew upto 6 plies of such materials at the high speed of 6,500 stitches per minute.

3. Silicone oil to be used

Silicone oil Viscosity: 500 cs

50cc silicone oil could be operated approximately half a month of sewing operation although it depends on the sewing work.

4. Proper installation on the machine

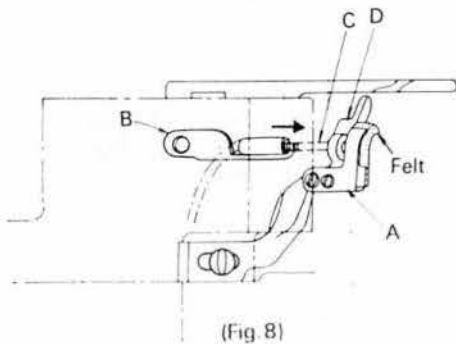

(Fig 8)

1) Installation of felt support and tube guide

Felt support is installed on needle guard front D as shown in Fig. 8.

Tube guide B should be installed on needle plate support deck with fully inserting the tube into the hole of the needle guard D because the tube C is fixed.

2) Position of tank

The position of tank should be set up at the position that the Vent hole is higher than the oil level as shown in Fig. 7.

5. Removal of the top cover

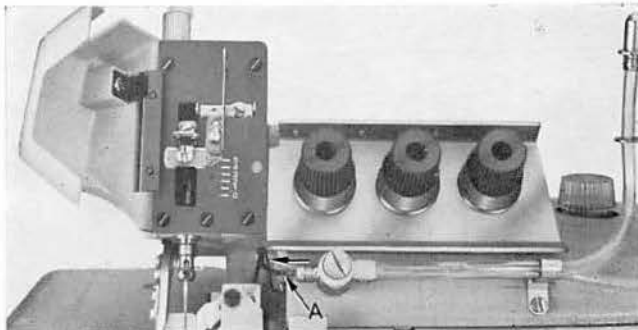

(Fig. 9)

When you pull the tube Point A to the left as shown in Fig. 9, the tank and felt portions will be separated, thus the tank can be detachable together with top cover.

F. Machine operating direction

The proper operating direction of this machine is clockwise as viewed from the pulley side.

G. Installing needle

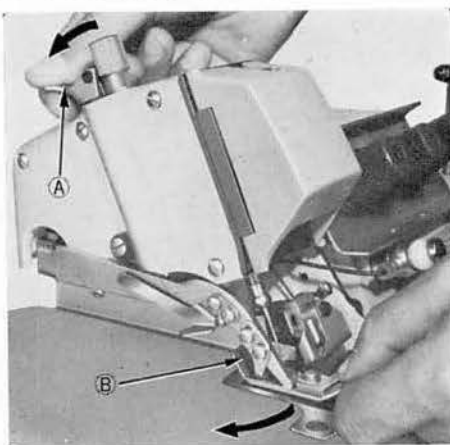

(Fig. 10)

Turn the pulley until the needle bar is raised to its highest position, lower the lifter lever A shown in Fig. 10 pressing by the thumb finger and move presser foot arm B to the direction as indicated with arrow mark.

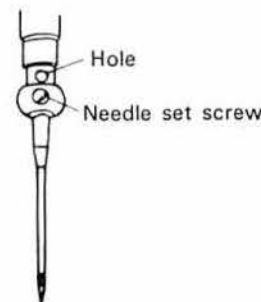

(Fig. 11)

New, loosen the needle set screw and holding the needle with its grooved side facing toward you, then insert the needle into the needle clamp hole all the way up checking the hole in the needle clamp whether the needle is all the way up. After this check, tighten the screw.

H. Threading

Pass the threads through the eyes of cotton stand then please do in the following order;

(1) Under looper (2) Over looper (3) Needle

Before passing these thread, open the front cover, cloth plate, and thread take-up cover, turn the pulley until the needle is at the highest position, and the presser foot arm outward. Pass the threads as shown in Fig. 12.

When you threads to the eyes of thread guides, loopers and needle, please use with the tweezers in the accessory box.

Draw out the thread approximate 5cm from the tip of looper.

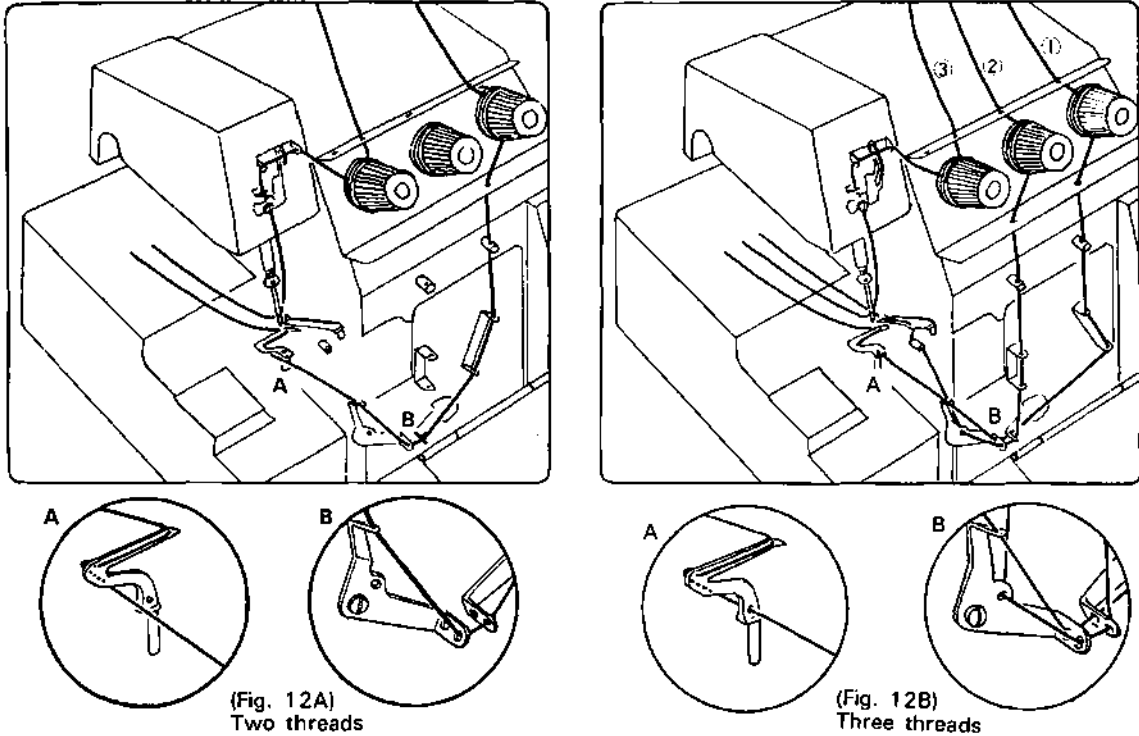

※Care should be taken for threading of two threads and three threads because differences between both cases are existed as in Figure A and B.

I. Stitches

E13 for B956-01 Three threads overeding tension (Figure 13)

E13A for B956-09 Three threads blind-hemming tension (Figure 14)

E12A for B956-11 Two threads serging tension (Figure 15)

E13 or E13A can be obtained with with readjusting the adjusting screw.



(Fig. 13)

E13A

In case of E13, the needle thread tension is the strongest, then the under looper thread tension and over looper thread tension is the weakest.



(Fig. 14)

E13A

In case of E13A, under looper thread tension is the strongest, then over looper thread tension and the needle thread tension is the weakest.



(Fig. 15)

E12A

In case of E12A, the needle thread tension is the weakest, then the under looper thread tension.

J. Thread tension

Thread tension may change depending on the type of thread and materials sewn, stitch width, stitch length, the position of the thread take-up and thread guides. If it should change considerably, make adjustment in the following manner.

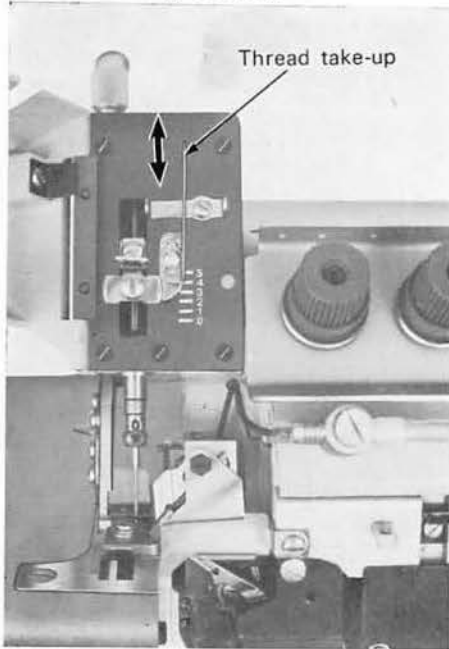

(Fig. 16)

1. Adjustment of thread take-up

To tighten the needle thread, lower the needle thread take-up.
To loosen it, raise the take-up.

The thread take-up in the middle position is the standard thread tension. (Fig. 16)

Note:

Thread take-up will be used in such way that three threads type (Figure A) is for B956-01 and B956-09, and two threads type (Figure B) is for B956-11.



A



B

2. Adjusting looper thread take-up and thread guide

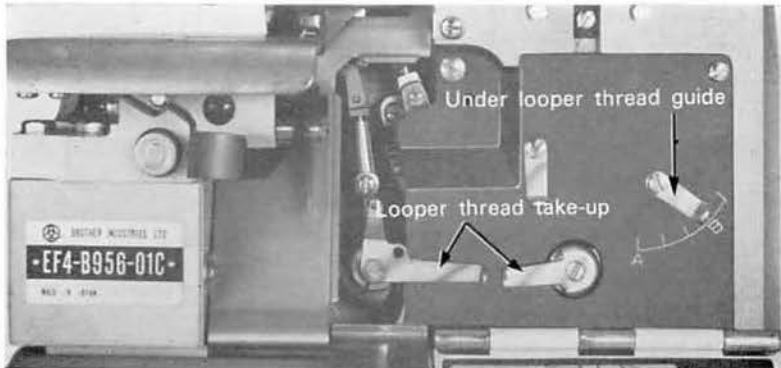

(Fig. 17)

As shown in Fig. 17, at the highest position of the needle, it is the standard position of the looper thread take-up and thread guide, for three threads use. In this case, the position of under looper thread guide shows in B is for cotton thread and A for synthetic thread.

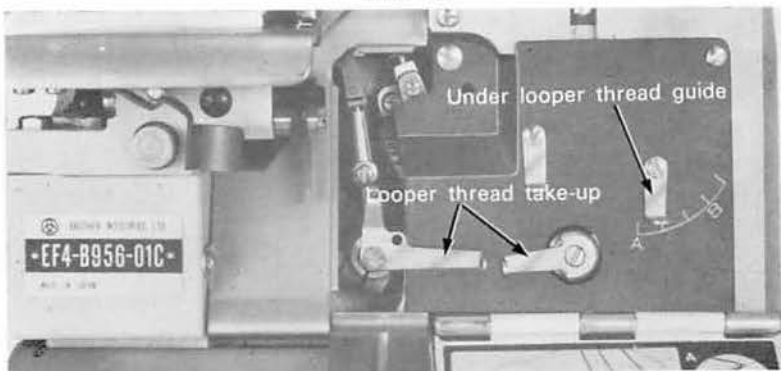

(Fig. 18)

As shown in Fig. 18, at the highest position of the needle, it is the standard position of the looper thread take-up and thread guide, for the two threads use.

3. Adjusting thread tension screws:

After completion of the above-mentioned adjustment of the thread guides, and thread take-up, turn the thread tension screw for fine adjustment. Incorporate an appropriate adjustment for the above "Stitches" (Page 14). Be careful not to turn the screw in or out excessively, because it may tighten the threads more than necessary or cause the thread take-up to feed threads too excessively.

K. Adjustment on the pressure of presser foot: Installing or removing feed dogs: and Height of feed dogs:

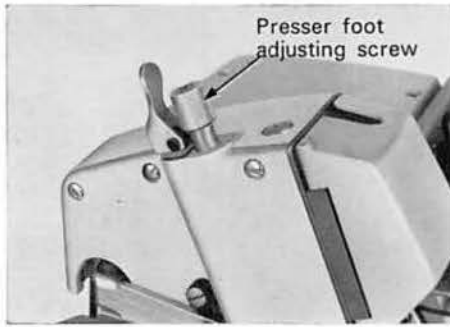

(Fig. 19)

The pressure of the presser foot can be adjusted by means of the presser foot adjusting screw shown in Fig. 19.

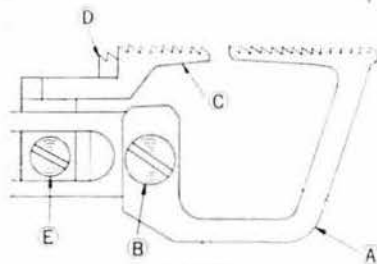

(Fig. 20)

To install the differential feed dog ①, tighten the screw ②. To install the main feed dog ③ and chaining-off feed dog ④, tighten the screw ⑤. (Fig. 20)

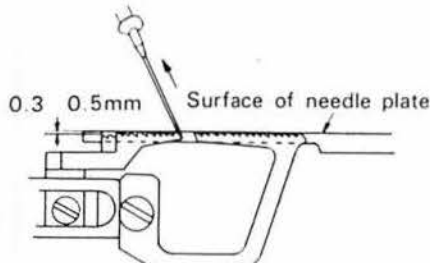

(Fig. 21)

The standard height of the feed dogs is such that when the needle point comes to fit perfectly to the top surface of the needle plate in its upward travelling, the top of the feed dogs is level with the surface of the needle plate. (Fig. 21)

L. Adjusting stitch width (bight)

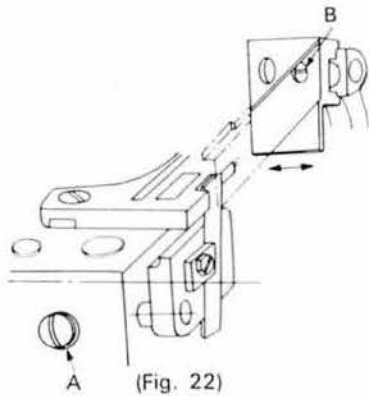

(Fig. 22)

Stitch width is dependent on cloth trimming width and the tongue of the needle plate.

Adjust the trimming width as follows: (Fig. 22)

- 1) Remove the upper knife.
- 2) Tighten the set screw A temporarily so that the lower knife may come to the point where desired trimming width may be obtained.
- 3) Loosen the screw B and adjust the contact of the upper and lower knives as shown in Fig. 23 by moving the upper knife holding block to either left or right.
- 4) Tighten the screw B and install the upper knife while pressing it to the lower knife.
- 5) Loosen the set screw A and please make sure that the lower knife may contact with upper knife by the spring pressure. Fix the lower knife by tightening the set screw A.

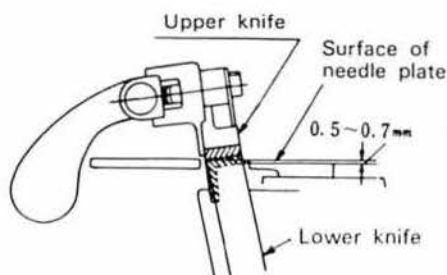

(Fig. 23)

M. Adjusting stitch length

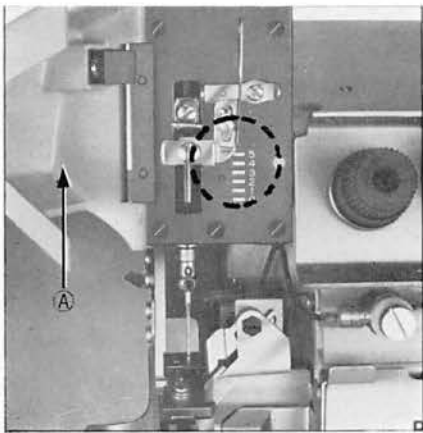

(Fig. 24)



(Fig. 25)

Stitch length can be adjusted to any point within the range from 1.7mm to 3.6mm for sub-class -01C, -09C, and from 1.7mm to 5.0mm for sub-class -11C. At first, open the needle thread take-up cover A. (Fig. 24) Then, with the push-button B located in front of the machine kept depressed, turn the button going inward as the pulley is turned.

Stop the pulley when the pointer reaches the number representing your desired stitch length, and release the push-button.

The numbers indicates the stitch length, however, actual stitch length may change depending on the kind of the materials, their thickness and differential feeding.

N. Adjusting differential feed

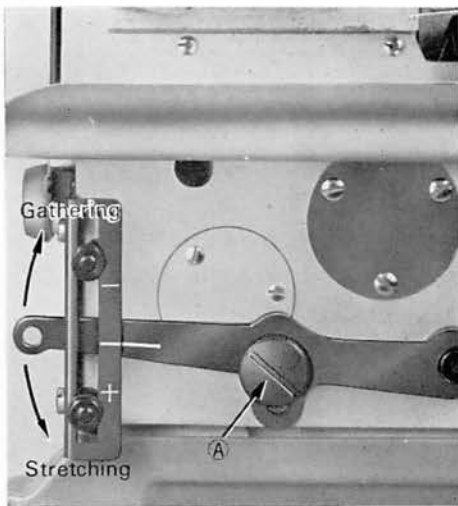

(Fig. 26A)

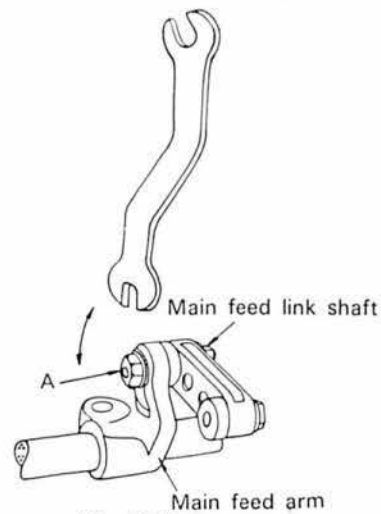

(Fig. 26B)

Differential feed may be adjusted to stretch be normal or gather by loosening the screw A shown in Fig. 26A and moving the lever up or down as required. Normal feed is obtained by setting the lever's mark in line with the mark on the scale. If the lever is lifted up, namely to (-) sign, you will get gathering.

If down, to (+) sign, you will get stretching. After adjustment is completed, please make sure to tighten the screw securely. In the case to require larger gathering differential feed.

Remove cloth plate and feeding mechanism cover, loosen nut A of main feed link shaft by an attached wrench, then lower downward. (Figure 26B) When the main feed link shaft is lowered until bottoming, the differential ratio will become as follows.

Differential adjusting lever, upper end.....Differential ratio, 2.5

Differential adjusting lever, lower end.....Differential ratio, 1.3

When a medium differential ratio is required, place and settle the main feed link shaft at an intermediate position in the groove of main feed arm.

4. Adjustment

A. Height of needle (Fig. 27)

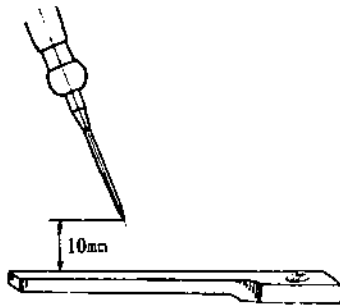

(Fig. 27)

For needle replacement, please follow the chapter describing the correct installation of the needle. When the needle is at the highest position, the needle should be 10mm over the surface of the needle plate.

B. Relation between needle and under looper

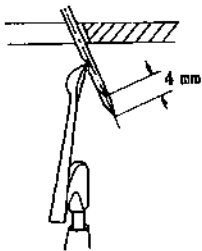

(Fig. 28A)

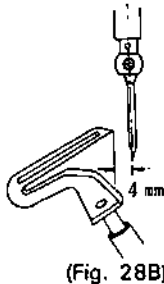

(Fig. 28B)

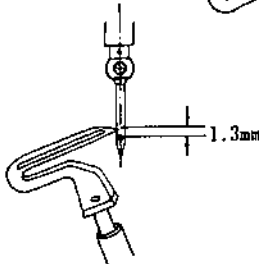

(Fig. 28C)

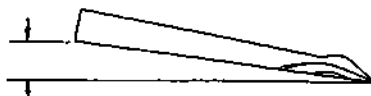

EF4-B956-01 } 2 mm
 EF4-B956-09 }
 EF4-B956-11 1.3mm

(Fig. 28D)

The tip of under looper and the center of needle will be aligned where the needle is raised up 4mm from the lower end.

(Figure 28A)

When the under looper is its left extremity, the distance between the point of the under looper and the centre of the needle is about 4mm (Fig. 28B).

The under looper is determined its height when it is inserted all the way into the looper holder.

The relation between the point of the under looper and the needle in its upward travelling is shown in Fig. 28C.

Also at this time, installation will be made so as to provide no clearance between the needle scoop and the tip of under looper. The under looper should be installed so as to be provided 2mm of inclination for B956-01 and 09, and 1.3mm of inclination for B956-11 (Fig. 28D).

C. Installing needle guard rear

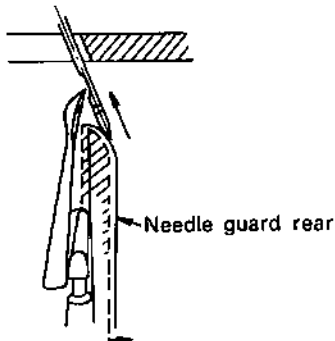

(Fig. 29A)

1. Set the point of the under looper to the center axis of the needle on its way up.
2. In this condition, install the needle guard rear in such a way that it may lightly contact with the needle.

If there is too big space between the point of the under looper and the needle, there may be skip stitch caused, for which please be careful enough not to bend the needle by pushing it with the needle guard.

D. Installing needle guard front

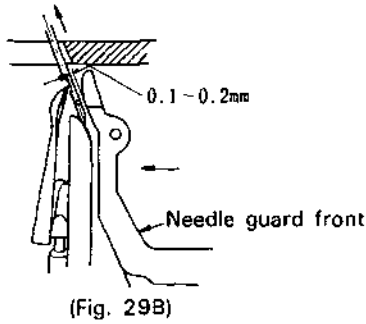

1. Set the point of the under looper to the center axis of the needle on its way up, same way as in the case of the needle guard rear.
2. In this condition, install the needle guard front in such a way that it will keep the space of approx. 0.1mm-0.2mm to the needle.

E. Relation of needle with under looper and over looper (Fig. 30)

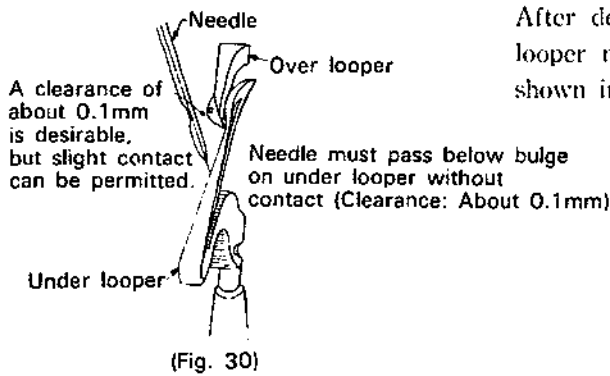

After determining the relative position of the needle and under looper mentioned in B, position the over looper properly as shown in Fig. 30.

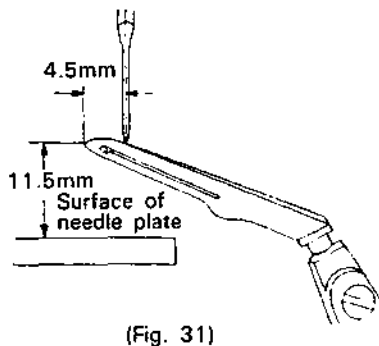
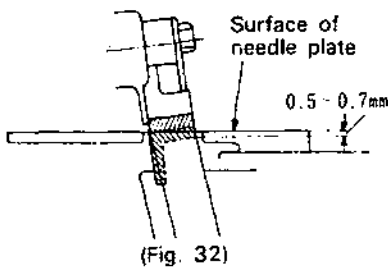
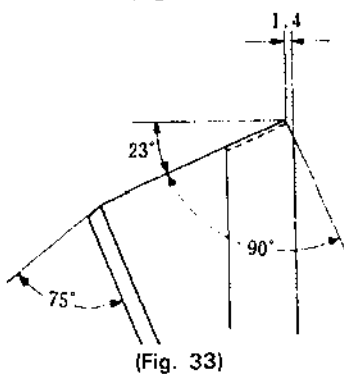

Fig. 31 shows the measurement of the over looper setting, for your reference.

F. Installing and maintenance of knives (Fig. 32)



Mount the lower knife to the lower knife holder so that its edge is level with the needle plate. Install the upper knife so that its front edge is 0.5-0.7mm below the edge of the lower knife when it is at the lowest end of its stroke as shown in Fig. 32. The upper knife is fitted with a tungsten-carbide tip, which can be ground only with diamond wheel. It lasts its original sharpness for a long period without resharpening. Sharpen the lower knife when necessary. Fig. 33 shows the shape of the lower knife.



5. Trouble-shooting

A. Thread break

Cause : Poor thread quality.

Remedy: Use thread of good quality.

Cause : Thread too thick for needle size.

Remedy: Change needle or thread for the right one.

Cause : Needle groove or needle eye poorly finished.

Remedy: Change needle for a good one.

Cause : Excessive pressure of tension disc.

Remedy: Adjust to proper pressure.

Cause : Needle improperly fitted.

Remedy: Refer to instruction for "Installing needle." (Page 5)

Cause : Needle, looper, needle plate, or thread passage has flaws.

Remedy: Smooth surface with oil stone or buff.

Cause : Relation of needle with looper and thread take-up not right.

Remedy: Refer to "Thread tension." (Page 7)

Cause : Wrong threading.

Remedy: Refer to "Threading." (Page 6)

Cause : Needle gets hot.

Remedy: Use with needle cooler or use smaller size needle.

B. Skip stitching

Cause : Wrong threading.

Remedy: Refer to "Threading." (Page 6)

Cause : Point of looper out of shape.

Remedy: Resharp with oil stone or replace.

Cause : Needle point blunt or bent.

Remedy: Replace.

Cause : Needle improperly fitted.

Remedy: Refer to "Installing needle." (Page 5)

Cause : Needle and needle guard out of proper relation.

Remedy: Refer to "Installing needle guard." (Page 10)

Cause : Needle gets hot.

Remedy: Use with needle cooler or use smaller size needle.

Cause : Pressure of tension disc too small.

Remedy: Adjust to proper pressure.

C. Needle break

Cause : Needle and needle guard out of proper relation.

Remedy: Refer to "Installing needle guard." (Page 10)

Cause : Needle and looper out of proper relation.

Remedy: Refer to "Relation between needle and under looper" and "Relation of needle with under looper and over looper." (Page 10 & 11)

Cause : Needle bent.

Remedy: Replace.

Cause : Needle improperly fitted.

Remedy: Refer to "Installing needle." (Page 5)

D. Imperfect chaining-off

Cause : Wrong threading.

Remedy: Refer to "Threading." (Page 6)

Cause : Stitch tongue on needle plate has flaw.

Remedy: Smooth with emery paper and polish with buff.

Cause : Looper thread take-up and thread guide out of position.

Remedy: Refer to "Thread tension." (Page 7)

Cause : Chain feed dog improperly installed.

Remedy: Refer to "Adjustment on the pressure of presser foot: Installing or removing feed dogs; and Height of feed dogs." (Page 8)

Cause : Thread too tight.

Remedy: Adjust to proper tension.

E. Improper thread tension

Cause : Relation of needle with looper and thread take-up not right.

Remedy: Refer to "Adjustment" and "Thread tension." (Page 10 & 7)

Cause : Tension disc will not work properly.

Remedy: Clean tension disc of foreign particles to allow smooth operation.

Cause : Thread too thick for needle.

Remedy: Use needle or thread of the right size.

Cause : Wrong threading.

Remedy: Refer to "Threading." (Page 6)

F. Poor trimming performance

Cause : Lower knife worn out.

Remedy: Re-sharpen. (Refer to "Fig. 33, Page 11")

Cause : Upper and lower knives installed improperly.

Remedy: Refer to "Installing and maintenance of knives." (Page 11)

Cause : Spring pressure on lower knife not right for materials to be trimmed.

Remedy: Refer to "Installing and maintenance of knives." (Page 11)

G. Irregular stitches

Cause : Wrong threading.

Remedy: Refer to "Threading." (Page 6)

Cause : Thread irregular in thickness.

Remedy: Use thread of good quality.

Cause : Thread passages rough.

Remedy: Smoothly polish.

Cause : Thread take-up and thread guide out of position.

Remedy: Refer to "Thread tension." (Page 7)

Cause : Knives blunt.

Remedy: Refer to "Installing and maintenance of knives." (Page 11)

Cause : Lower knife installed improperly.

Remedy: Refer to "Installing and maintenance of knives." (Page 11)

H. Excessive wrinkles along stitches

Cause : Differential feed adjustment not right.

Remedy: Refer to "Adjusting differential feed." (Page 9)

Cause : Pressure of presser foot not right.

Remedy: Adjust to proper pressure.

Cause : Thread tension too strong.

Remedy: Adjust properly.

Cause : Feed dogs installed improperly.

Remedy: Refer to "Adjustment on pressure of presser foot; Installing and removing feet; dogs; and Height of feed dogs." (Page 8)

Cause : Knives blunt.

Remedy: Refer to "Installing and maintenance of knives." (Page 11)

Cause : Cloth trimming width and stitch tongue of needle plate out of proportion.

Remedy: Adjust trimming width to needle plate or replace needle plate.

Cause : Needle too thick.

Remedy: Use proper needle for materials and thread.

I. Needle produces to large hole

Cause : Needle point blunt.

Remedy: Replace needle.

Cause : Needle too large for materials.

Remedy: Use smaller size needle.

Cause : Needle gets hot.

Remedy: Use needle cooler.

PARTS LIST for EF4-B956C

INDEX

| Parts. No. | Ref. No. | Remark | Parts. No. | Ref. No. | Remark | Parts. No. | Ref. No. | Remark | Parts. No. | Ref. No. | Remark |
|-------------|----------|--------|--------------|----------|--------|-------------|----------|--------|-------------|----------|--------|
| 001401-4-06 | Z-33 | | 100541-0-02 | E-41 | | 112300-0-01 | F-6 | | 140116-0-00 | C-1 | |
| 003670-6-14 | C-47 | | | | | 112301-0-01 | F-8 | | | | C-26 |
| | D-11 | | 100541-0-03 | A-5 | | 112348-0-01 | A-91 | | 140117-0-01 | C-38 | |
| | F-31 | | 100644-0-03 | A-81 | | | G-2 | | 140118-0-00 | C-13 | |
| 005660-7-13 | D-40 | | 101532-0-01 | B-62 | | | G-15 | | | | C-39 |
| 009639-4-12 | F-83 | | 101572-0-01 | Z-10 | | | G-17 | | 140119-0-01 | C-44 | |
| 009660-6-14 | H-3 | | 101629-0-02 | I-27 | | | G-22 | | 140120-0-01 | C-45 | |
| 009669-3-13 | F-5 | | | J-28 | | | H-15 | | 140121-0-01 | C-49 | |
| 009670-5-16 | A-98 | | 101706-0-01 | A-45 | | 112351-0-01 | G-20 | | 140122-0-01 | C-50 | |
| 009680-8-12 | G-56 | | | D-26 | | 112364-0-01 | G-5 | | 140124-0-01 | C-21 | |
| 009681-0-14 | A-20 | | | G-50 | | | G-16 | | 140125-0-01 | C-23 | |
| 009681-2-12 | D-88 | | 101795-0-01 | Z-26 | | 112364-0-01 | G-21 | | 140127-0-01 | C-48 | |
| 009682-0-14 | A-22 | | 102538-0-06 | A-49 | | 112467-0-01 | A-82 | | 140128-0-01 | C-49-50 | |
| 009689-4-12 | G-57 | | 102629-0-04 | Z-9 | | 112751-0-01 | A-99 | | 140129-0-01 | C-6-8 | |
| 009711-0-13 | C-24 | | 102843-0-04 | A-10 | | 112836-0-01 | J-26 | | 140130-0-01 | C-6 | |
| 013750-6-14 | E-61 | | | A-11 | | 113392-0-01 | E-4 | | 140152-0-01 | A-7 | |
| 014660-3-22 | B-69 | | 104215-0-01 | E-48 | | | Z-21 | | 140165-0-01 | D-98 | |
| 017751-4-13 | C-16 | | 104449-0-01 | A-36 | | 113431-0-02 | D-3 | | 140176-0-01 | D-95 | |
| 017771-4-12 | D-15 | | 104521-0-01 | D-27 | | | D-110 | | 140178-0-01 | D-9 | |
| | D-23 | | | G-59 | | 114294-0-01 | B-36 | | 140179-0-01 | D-8 | |
| | D-55 | | 104564-0-01 | JL-13 | | 114483-0-01 | Z-14 | | 140180-0-01 | B-44 | |
| 017771-6-12 | C-5 | | 104651-0-01 | C-46 | | 114727-0-01 | J-9 | | 140182-0-01 | D-78 | |
| | C-31 | | 104832-0-01 | A-46 | | 114855-0-01 | J-25 | | 140183-0-01 | D-80 | |
| | C-51 | | 104833-0-01 | G-8 | | 115811-0-01 | A-73 | | 140184-0-01 | D-7 | |
| | D-10 | | 105034-0-02 | C-10 | | 116016-0-01 | Z-32 | | 140185-0-00 | D-6 | |
| | B-16 | | | C-36 | | 116231-0-01 | A-55 | | 140186-0-00 | D-24 | |
| | E-19 | | 105078-0-01 | B-22 | | 116662-0-01 | D-59 | | 140187-0-00 | A-47 | |
| | E-64 | | 105079-0-01 | B-19 | | 116778-0-01 | C-3 | | 140188-0-02 | A-48 | |
| 017782-0-14 | B-60 | | 105123-0-01 | F-28 | | | C-27 | | 140189-0-01 | D-37-38 | |
| 017822-2-13 | A-85 | | | J-23 | | 117026-0-01 | A-100 | | 140190-0-01 | D-37 | |
| 021080-1-06 | Z-40 | | 105163-0-01 | D-29 | | 117437-0-01 | Z-31 | | 140191-0-01 | D-38 | |
| 021400-1-06 | Z-34 | | 105173-0-03 | G-40 | | 117466-0-00 | Z-11 | | 140193-0-01 | D-90 | |
| 025080-3-36 | Z-38 | | 105248-0-01 | F-37 | | 117515-0-01 | E-51 | | 140196-0-00 | D-83 | |
| 025350-3-32 | G-44 | | 105343-0-0-1 | Z-3 | | 117516-0-01 | E-50 | | 140197-0-01 | D-85 | |
| 028080-2-43 | Z-39 | | 105827-0-01 | C-20 | | 118527-0-01 | E-49 | | 140202-0-01 | D-28 | |
| 031451-6-03 | Z-28 | | 106069-0-01 | C-25 | | | Z-18 | | 140203-0-01 | D-39 | |
| 048020-3-42 | E-74 | | 106069-0-03 | E-31 | | 120048-0-02 | E-1 | | 140205-0-01 | D-22 | |
| 048050-3-42 | H-11 | | 106129-0-01 | B-61 | | | E-3 | | 140207-0-01 | D-35 | |
| | D-113 | | 106568-0-01 | I-26 | | 120823-0-01 | E-45 | | 140208-0-01 | D-32 | |
| 048080-3-42 | E-24 | | 106812-0-01 | Z-30 | | 140032-0-01 | A-32 | | | | D-44 |
| 048150-1-43 | D-107 | | 107093-0-01 | D-97 | | 140033-0-01 | A-31 | | 140209-0-01 | D-36 | |
| 072600-0-30 | B-33 | | 107231-0-01 | E-82 | | 140036-0-01 | A-6 | | 140210-0-01 | D-34 | |
| 072600-1-00 | B-70 | | 107244-0-01 | B-52 | | 140037-0-02 | A-13-17 | | 140211-0-01 | D-14-19 | |
| 081004-0-70 | H-29 | | 107272-0-02 | A-28 | | 140038-0-02 | A-16 | | 140212-0-01 | D-16 | |
| 100016-0-03 | B-46 | | 107351-0-01 | B-59 | | 140039-0-01 | A-13 | | 140213-0-01 | D-19 | |
| 100025-0-01 | D-108 | | 107407-0-02 | D-87 | | 140040-0-01 | A-17 | | 140214-0-01 | D-18 | |
| 100032-0-01 | A-40 | | 107491-0-02 | I-21 | | 140041-0-01 | A-15 | | 140215-0-01 | D-42 | |
| | B-57 | | 107779-0-01 | Z-5 | | 140042-0-01 | A-12 | | 140216-0-01 | D-43 | |
| 100035-0-01 | F-12 | | 108721-0-01 | F-21 | | 140043-0-01 | A-9 | | 140217-0-01 | D-45 | |
| | H-32 | | 108902-0-01 | Z-23 | | 140045-0-01 | A-37 | | 140226-0-01 | D-58 | |
| 100080-0-02 | E-37 | | 109203-0-01 | A-86 | | 140048-0-01 | A-29 | | 140228-0-01 | D-4 | |
| | I-7 | | 109836-0-01 | H-17 | | 140054-0-03 | A-77 | | 140229-0-01 | D-5 | |
| | J-5 | | 110161-0-04 | D-2 | | 140055-0-01 | A-80 | | 140230-0-01 | E-65-69 | |
| 100105-0-02 | E-34 | | | E-32 | | 140056-0-01 | A-79 | | 140231-0-00 | E-68 | |
| | I-6 | | | H-27 | | 140057-0-01 | A-74 | | 140232-0-01 | E-65 | |
| | J-5 | | 110191-0-01 | H-26 | | 140063-0-01 | B-56 | | 140233-0-01 | F-66 | |
| 100130-0-01 | A-18 | | 110436-0-01 | Z-1 | | 140064-0-01 | A-27 | | 140235-0-00 | E-60 | |
| 100137-0-01 | G-43 | | 110495-0-03 | A-44 | | 140065-0-01 | A-24 | | 140236-0-01 | E-62 | |
| 100137-0-02 | A-38 | | 110641-0-01 | A-87 | | 140067-0-01 | A-89 | | 140238-0-01 | E-58 | |
| | B-64 | | 110668-0-01 | B-41 | | 140071-0-01 | A-84 | | 140240-0-01 | E-54 | |
| 100185-0-03 | A-24 | | 110670-0-00 | B-48 | | 140072-0-01 | A-82 | | 140241-0-01 | E-53 | |
| | A-51 | | 110672-0-00 | B-50 | | 140075-0-01 | A-52 | | | | I-13 |
| | G-7 | | 110673-0-00 | B-51 | | 140077-0-01 | A-83 | | 140242-0-01 | E-55 | |
| | G-11 | | 110686-0-01 | B-15 | | 140083-0-01 | A-61 | | | | I-12 |
| 100185-0-04 | A-58 | | | E-67 | | 140084-0-00 | B-43 | | 140246-0-01 | E-43 | |
| | A-65 | | 110701-0-01 | C-9 | | 140085-0-02 | B-15 | | 140247-0-01 | E-47 | |
| | A-71 | | | C-35 | | 140088-0-01 | B-11 | | 140248-0-01 | E-42 | |
| | A-75 | | 110706-0-01 | C-14 | | 140089-0-01 | B-12 | | 140261-0-01 | E-20 | |
| | F-2 | | 110735-0-01 | A-8 | | 140090-0-01 | B-7 | | 140262-0-00 | E-25 | |
| | F-16 | | | D-111 | | 140091-0-00 | B-17 | | 140263-0-00 | E-18 | |
| | H-4 | | 110793-0-01 | E-23 | | 110092-0-01 | B-8 | | 140264-0-01 | E-17 | |
| | H-19 | | 110806-0-01 | E-39 | | 140093-0-00 | B-3 | | 140267-0-01 | E-6 | |
| 100215-0-00 | D-100 | | | I-9 | | 140094-0-01 | B-24 | | 140277-0-01 | E-31 | |
| 100218-0-02 | A-95 | | 110807-0-01 | E-38 | | 140095-0-01 | B-1 | | 140278-0-01 | F-24 | |
| 100242-0-02 | A-14 | | | I-8 | | 140096-0-01 | B-26 | | 140281-0-01 | F-13 | |
| 100251-0-01 | D-61 | | | J-8 | | 140097-0-01 | B-2 | | 140286-0-01 | F-30 | |
| 100260-0-01 | B-4 | | 110815-0-01 | F-19 | | 140098-0-01 | B-25 | | 140305-0-01 | G-47 | |
| 100264-0-04 | B-67 | | 110820-0-01 | F-23 | | 140099-0-01 | B-28 | | 140314-0-01 | G-9 | |
| 100289-0-01 | C-2 | | 110821-0-01 | F-25 | | 140100-0-01 | B-29 | | 140317-0-00 | E-63 | |
| 100289-0-03 | C-28 | | 110822-0-01 | F-26 | | 140102-0-01 | F-3 | | 140320-0-00 | B-10 | |
| 100366-0-01 | B-9 | | 110823-0-01 | F-32 | | 140103-0-01 | F-1 | | 140325-0-01 | G-1 | |
| | B-13 | | 111104-0-01 | D-63 | | 140106-0-01 | B-34 | | 140326-0-01 | B-6 | |
| | E-69 | | 111443-0-01 | A-94 | | 140109-0-01 | A-25 | | 140328-0-01 | B-23 | |
| 100368-0-02 | B-47 | | | C-17 | | 140110-0-00 | A-26 | | | | H-11 |
| 100469-0-02 | A-53 | | | C-20 | | 140111-0-01 | C-32-34 | | 140327-0-01 | B-18 | |
| 100539-0-03 | D-57 | | 111486-0-01 | B-58 | | 140112-0-00 | C-8 | | | | C-4 |
| 100541-0-01 | B-20 | | 111865-0-01 | A-93 | | | C-34 | | | | C-40 |
| | G-10 | | 112297-0-11 | B-42 | | | C-32 | | 140328-0-01 | A-72 | |
| 100541-0-02 | B-66 | | 112297 | Z-24 | | 140114-0-00 | C-19 | | 140341-0-01 | A-70 | |
| | D-1 | | 112298-0-01 | F-7 | | 140115-0-01 | C-41 | | 140342-0-01 | Z-2 | |

| | | | | | | | |
|-------------|---------|-------------|---------------|--|--|--|--|
| 142589-0-01 | D 13 | 144108-0-01 | F 32 | | | | |
| 142588-0-01 | D 54 | 144106-0-01 | F 34 | | | | |
| 142574-0-01 | H 84 | 144105-0-00 | F 35 | | | | |
| 142412-0-01 | H 10 | 144103-0-01 | F 36 | | | | |
| 142348-0-01 | H 15 | 144092-0-01 | H 56 | | | | |
| 142346-0-01 | H 53 | 144088-0-01 | F 81 | | | | |
| 142343-0-01 | Z 15 | 144087-0-01 | F 71 | | | | |
| 142344-0-01 | Z 56 | 144086-0-01 | F 76 | | | | |
| 142330-0-01 | H 38 | 144085-0-01 | E 77 | | | | |
| 142321-0-01 | H 22 | 144084-0-01 | E 73 | | | | |
| 142317-0-01 | H 14 | 144083-0-01 | F 75 | | | | |
| 142316-0-01 | H 23 | 144082-0-01 | F 72 | | | | |
| 142294-0-02 | H 55 | 144081-0-01 | F 80 | | | | |
| 142293-0-01 | H 17 | 144080-0-01 | E 79 | | | | |
| 142287-0-01 | H 7 9 | 144079-0-01 | E 78 | | | | |
| 142286-0-01 | H 1 | 144056-0-01 | D 106 | | | | |
| 142285-0-01 | H 2 | 144055-0-01 | D 105 | | | | |
| 142284-0-01 | H 19 | 144053-0-01 | D 104 | | | | |
| 142282-0-01 | H 12 | 143992-0-01 | A 100 | | | | |
| 142281-0-01 | H 16 | 143991-0-01 | A 99 | | | | |
| 142277-0-01 | J 11 | 143912-0-01 | H 6 | | | | |
| 142260-0-01 | D 82 | 143785-0-01 | I 44 | | | | |
| 142259-0-01 | H 30 | 143781-0-01 | A 76 | | | | |
| 142201-0-01 | I 4 | 143774-0-01 | A 78 | | | | |
| 142200-0-01 | J 10 | 143770-0-01 | A 98 | | | | |
| 142199-0-01 | J 5 11 | 143768-0-01 | F 27 | | | | |
| 142198-0-01 | J 12 | 143761-0-01 | B 30 | | | | |
| | | 143761-0-01 | B 29 30 69 | | | | |
| 142197-0-01 | D 92 | 143760-0-01 | H 5 | | | | |
| 142196-0-01 | J 17 | 143759-0-01 | C 15 | | | | |
| 142192-0-01 | J 15 | 143758-0-01 | C 54 | | | | |
| 142191-0-01 | J 15 | 143757-0-01 | F 9 | | | | |
| 142186-0-01 | J 27 | 143753-0-01 | H 63 | | | | |
| 142185-0-01 | J 24 | 143752-0-01 | H 66 | | | | |
| 142184-0-01 | J 20 27 | 143734-0-01 | C 53 | | | | |
| 142182-0-01 | A 60 | 143733-0-01 | C 29 | | | | |
| 142125-0-00 | Z 12 | 143704-0-01 | A 97 | | | | |
| 141657-0-00 | H 33 | 143703-0-01 | A 63 | | | | |
| 141188-0-01 | D 12 | 143666-0-01 | Z 4 | | | | |
| 141183-0-00 | A 43 | 143665-0-01 | D 20 | | | | |
| 140928-0-00 | H 25 | 143664-0-01 | D 33 | | | | |
| 140913-0-01 | A 19 | 143652-0-01 | J 20 22 | | | | |
| 140888-0-01 | E 2 | 143551-0-02 | A 69 | | | | |
| 140798-0-01 | Z 25 | 143545-0-02 | I 29 | | | | |
| 140792-0-01 | Z 27 | 143538-0-01 | A 101 | | | | |
| | | 143537-0-01 | A 29 | | | | |
| 140782-0-01 | G 13 | 143536-0-01 | A 30 | | | | |
| 140781-0-01 | G 4 | 143534-0-01 | I 6 | | | | |
| | | 143442-0-01 | E 70 | | | | |
| 140780-0-01 | G 3 | 143375-0-01 | A 50 | | | | |
| 140778-0-01 | C 18 | 143374-0-01 | A 41 | | | | |
| | | 143372-0-01 | A 42 | | | | |
| | | 143371-0-01 | A 40 42 | | | | |
| 140774-0-00 | C 52 | 143327-0-01 | H 21 | | | | |
| 140772-0-01 | D 41 | 143326-0-01 | H 22 | | | | |
| 140771-0-01 | D 31 | 143325-0-01 | E 29 | | | | |
| 140768-0-01 | G 14 | 143324-0-01 | E 28 | | | | |
| 140764-0-01 | G 12 | 143323-0-01 | E 28 | | | | |
| 140759-0-00 | Z 17 | 143320-0-01 | E 59 | | | | |
| 140758-0-00 | A 88 | 143312-0-01 | H 34 | | | | |
| 140739-0-01 | Z 27 | 143311-0-01 | B 35 | | | | |
| 140738-0-01 | Z 36 | 143294-0-02 | A 90 | | | | |
| | | 143293-0-01 | A 33 | | | | |
| 140708-0-00 | C 11 | 143292-0-02 | A 21 | | | | |
| | | 143287-0-01 | D 60 | | | | |
| 140504-0-01 | F 5 | 143289-0-01 | J 30 | | | | |
| 140468-0-01 | G 82 | 143267-0-01 | A 54 | | | | |
| 140463-0-01 | E 35 | 143183-0-01 | H 38 | | | | |
| 140462-0-01 | E 40 | 143179-0-00 | H 40 | | | | |
| 140461-0-01 | E 36 | 143174-0-00 | H 37 | | | | |
| 140460-0-01 | C 24 40 | 143161-0-01 | I 24 | | | | |
| 140458-0-01 | E 44 | 143160-0-01 | I 25 | | | | |
| 140457-0-01 | E 82 | 143158-0-01 | I 22 24 | | | | |
| 140455-0-01 | E 57 | 143157-0-01 | I 20 | | | | |
| 140453-0-01 | D 112 | 143156-0-01 | I 20 26 | | | | |
| 140451-0-01 | I 18 | 143155-0-01 | I 10 | | | | |
| | | 143154-0-01 | I 11 | | | | |
| 140450-0-01 | D 91 | 143153-0-01 | I 5 11 | | | | |
| 140446-0-01 | H 53 | 143152-0-01 | I 19 | | | | |
| 140445-0-01 | H 53 | 143151-0-01 | I 14 | | | | |
| 140444-0-01 | H 53 | 143150-0-01 | I 15 | | | | |
| 140425-0-01 | H 27 | 142977-0-01 | Z 41 | | | | |
| 140421-0-01 | A 67 | 142976-0-01 | H 24 | | | | |
| 140420-0-00 | D 14 | | J 6 | | | | |
| 140419-0-00 | C 22 | 142782-0-01 | I 6 | | | | |
| 140418-0-00 | H 5 | 142674-0-00 | D 82 | | | | |
| | | 142673-0-01 | D 81 | | | | |
| 140417-0-00 | A 66 | 142669-0-01 | F 11 | | | | |
| 140416-0-00 | C 42 | | C 33 | | | | |
| 140415-0-00 | H 21 | 142590-0-01 | C 7 | | | | |
| | | | F 33 | | | | |
| | | | Z 7 | | | | |
| | | | Z 16 | | | | |
| | | | C 42 57 | | | | |
| | | | C 45 | | | | |
| | | | C 42 | | | | |
| | | | G 46 | | | | |
| | | | C 51 | | | | |
| | | | G 48 | | | | |
| | | | G 53 | | | | |
| | | | G 54 | | | | |
| | | | C 55 | | | | |
| | | | D 101 | | | | |
| | | | D 99 | | | | |
| | | | D 96 | | | | |
| | | | D 99 | | | | |
| | | | D 102 | | | | |
| | | | H 11 13 15 68 | | | | |
| | | | H 68 | | | | |
| | | | D 109 | | | | |
| | | | A 102 | | | | |
| | | | H 1 33 | | | | |
| | | | C 2 3 | | | | |
| | | | C 27 28 | | | | |
| | | | D 26 27 | | | | |
| | | | D 26 27 | | | | |
| | | | F 10 | | | | |
| | | | G 41 | | | | |
| | | | 500693-0-01 | | | | |

A

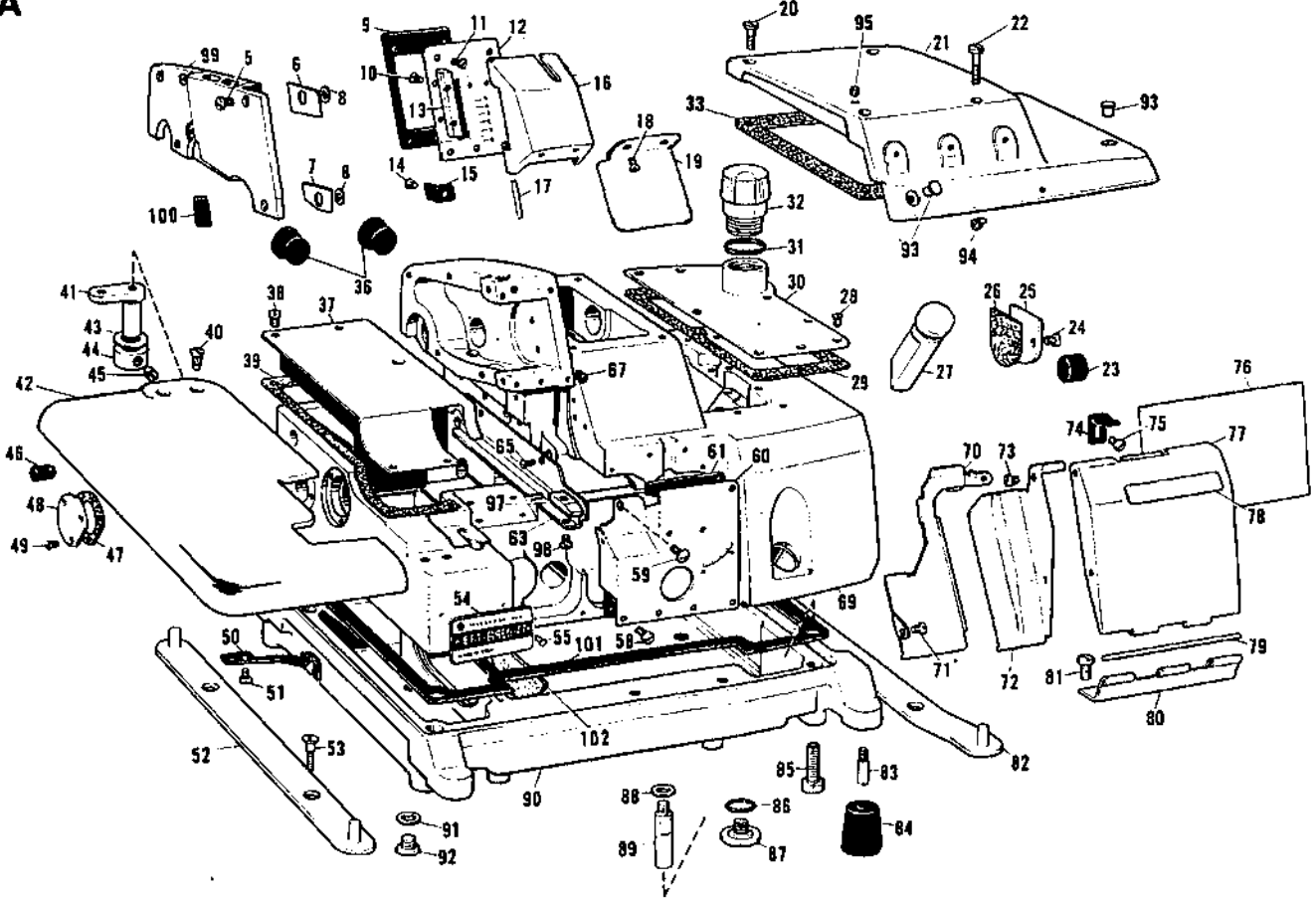

PARTS LIST for EF4-B956-01C

| Ref. No. | Name of Parts | Qty | Parts No. | Assembly No. | Ref. No. | Name of Parts | Qty | Parts No. | Assembly No. |
|----------|--|---------|-------------|--------------|----------|-------------------------------------|--------|-------------|--------------|
| A-5 | Set Screw for A-99 | 6 pcs. | 100541-0-03 | | A-52 | Cushion Base (Left) | 1 pce. | 140075-0-01 | |
| A-6 | Cover Packing (Upper) for A-4 | 1 pce. | 140036-0-01 | | A-53 | Set Screw 5.1x26 | 4 pcs. | 100469-0-02 | |
| A-7 | Cover Packing (Lower) for A-4 | 1 " | 140152-0-01 | | A-54 | Model Plate (B956-01C) | 1 pce. | 143267-0-01 | |
| A-8 | Washer for A-4 | 2 pcs. | 110735-0-01 | | A-55 | Pin for A-54 | 2 pcs. | 116231-0-01 | |
| A-9 | Face Plate Packing | 1 pce. | 140043-0-01 | | A-58 | Set Screw for A-60 | 5 " | 100185-0-04 | |
| A-10 | Flat Head Screw for A-11 | 2 pcs. | 102843-0-04 | | A-59 | Set Screw for A-60 | 1 pce. | 112751-0-01 | |
| A-11 | Flat Head Screw for A-12 | 5 " | 102843-0-04 | | A-60 | Inside Cover | 1 " | 142182-0-01 | |
| A-12 | Face Plate | 1 pce. | 140042-0-01 | | A-61 | Packing for A-60 | 1 " | 140083-0-01 | |
| A-13 | Hinge for A-16 | 1 " | 140039-0-01 | | A-63 | Cloth Guide | 1 " | 143703-0-01 | |
| A-14 | Set Screw for A-15 | 1 " | 100342-0-02 | | A-65 | Flat Head Screw for A-63 | 2 pcs. | 100185-0-04 | |
| A-15 | Stopper Spring for A-16 | 1 " | 140041-0-01 | | A-66 | Wick 6x6 | 1 pce. | 140417-0-00 | |
| A-16 | Needle Thread Take-up Cover | 1 " | 140038-0-02 | 140037-0-02 | A-67 | Oil Cup 6.3x10 | 1 " | 140421-0-01 | |
| A-17 | Pin for A-11 | 2 pcs. | 140040-0-01 | | A-69 | Machine Body | 1 " | 143551-0-02 | |
| A-18 | Set Screw for A-19 | 2 " | 100130-0-01 | | A-70 | Looper Cover (A) | 1 " | 140341-0-01 | |
| A-19 | Eye Guard | 1 pce. | 140913-0-01 | | A-71 | Set Screw for A-70 | 2 pcs. | 100185-0-04 | |
| A-20 | Set Screw for A-21 | 2 pcs. | 009681-0-04 | | A-72 | Looper Cover (B) | 1 pce. | 140328-0-01 | |
| A-21 | Top Cover | 1 pce. | 143292-0-02 | | A-73 | Set Screw for A-72 | 2 pcs. | 115811-0-01 | |
| A-22 | Set Screw for A-21 | 2 pcs. | 009682-0-04 | | A-74 | Stopper Spring for A-77 | 1 pce. | 140057-0-01 | |
| A-23 | Oil Cap 14.3x10 | 2 " | 140065-0-01 | | A-75 | Set Screw for A-74 | 1 " | 100185-0-04 | |
| A-24 | Set Screw for A-25 | 2 " | 100185-0-03 | | A-76 | Threading Diagram for Three Threads | 1 " | 143781-0-01 | |
| A-25 | Cover for Needle Shaft Bushing (Right) | 1 pce. | 140109-0-01 | | A-77 | Front Cover | 1 " | 140054-0-03 | |
| A-26 | Packing for A-25 | 1 " | 140110-0-00 | | A-78 | Name Plate | 1 " | 143774-0-01 | |
| A-27 | Oil Gauge | 1 " | 140064-0-01 | | A-79 | Pin for A-80 | 1 " | 140056-0-01 | |
| A-28 | Flat Head Screw for A-30 | 10 pcs. | 107272-0-02 | | A-80 | Hinge for Front Cover | 1 " | 140055-0-01 | |
| A-29 | Packing for Dust Cover (Right) | 1 pce. | 143537-0-01 | | A-81 | Set Screw for A-80 | 2 pcs. | 100644-0-03 | |
| A-30 | Dust Cover (Right) | 1 " | 143536-0-01 | | A-82 | Cushion Base (Right) | 1 pce. | 140072-0-01 | |
| A-31 | Packing for A-32 | 1 " | 140033-0-01 | | A-83 | Set Pin for Cushion | 4 pcs. | 140077-0-01 | |
| A-32 | Cap for Oil Feeding Hole | 1 " | 140032-0-01 | | A-84 | Cushion | 4 " | 140071-0-01 | |
| A-33 | Packing for A-21 | 1 " | 143293-0-01 | | A-85 | Hexagonal Bolt SM 7.94-28x22 | 4 " | 017822-2-13 | |
| A-36 | Oil Cup | 2 pcs. | 104449-0-01 | | A-86 | Rubber Packing for A-87 | 1 pce. | 109203-0-01 | |
| A-37 | Cover for Feed Mechanism | 1 pce. | 140045-0-01 | | A-87 | Set Screw for A-86 | 1 " | 110641-0-01 | |
| A-38 | Set Screw for A-37 | 4 pcs. | 100137-0-02 | | A-88 | Washer for A-89 | 4 pcs. | 140758-0-00 | |
| A-39 | Packing for A-37 | 1 pce. | 140048-0-00 | | A-89 | Machine Body Leg | 4 " | 140067-0-01 | |
| A-40 | Flat Head Screw for A-42 | 2 pcs. | 100032-0-01 | | A-90 | Oil Reservoir | 1 pce. | 143294-0-02 | |
| A-41 | Cloth Plate Supporter | 1 pce. | 143374-0-01 | 143371-0-01 | A-91 | Packing | 1 " | 112348-0-01 | |
| A-42 | Cloth Plate | 1 " | 143372-0-01 | | A-92 | Oil Draining Screw | 1 " | 112467-0-01 | |
| A-43 | Washer for A-44 | 1 " | 141183-0-00 | | A-93 | Cap | 2 pcs. | 111865-0-01 | |
| A-44 | Set Collar for A-41 | 1 " | 110495-0-03 | | A-94 | Set Screw | 1 pce. | 111443-0-01 | |
| A-45 | Set Screw for A-44 | 2 pcs. | 101706-0-01 | | A-95 | Set Screw | 1 " | 100218-0-02 | |
| A-46 | Oil Cap | 1 pce. | 104832-0-01 | | A-97 | Chain Guide | 1 " | 143704-0-01 | |
| A-47 | Packing for A-48 | 1 " | 140187-0-00 | | A-98 | Set Screw for A-97 | 1 " | 009670-5-16 | |
| A-48 | Cover for Feed Shaft Bushing (Left) | 1 " | 140188-0-02 | | A-99 | Cover for Needle Driving Mechanism | 1 " | 143591-0-01 | |
| A-49 | Flat Head Screw for A-48 | 3 pcs. | 102328-0-06 | | A-100 | Cap | 1 " | 143992-0-01 | |
| A-50 | Stopper Spring for A-42 | 1 pce. | 143375-0-01 | | A-101 | Packing for Oil Reservoir | 1 " | 143538-0-01 | |
| A-51 | Set Screw for A-50 | 2 pcs. | 100185-0-03 | | A-102 | Oil Filter | 1 " | 145664-0-00 | |

B

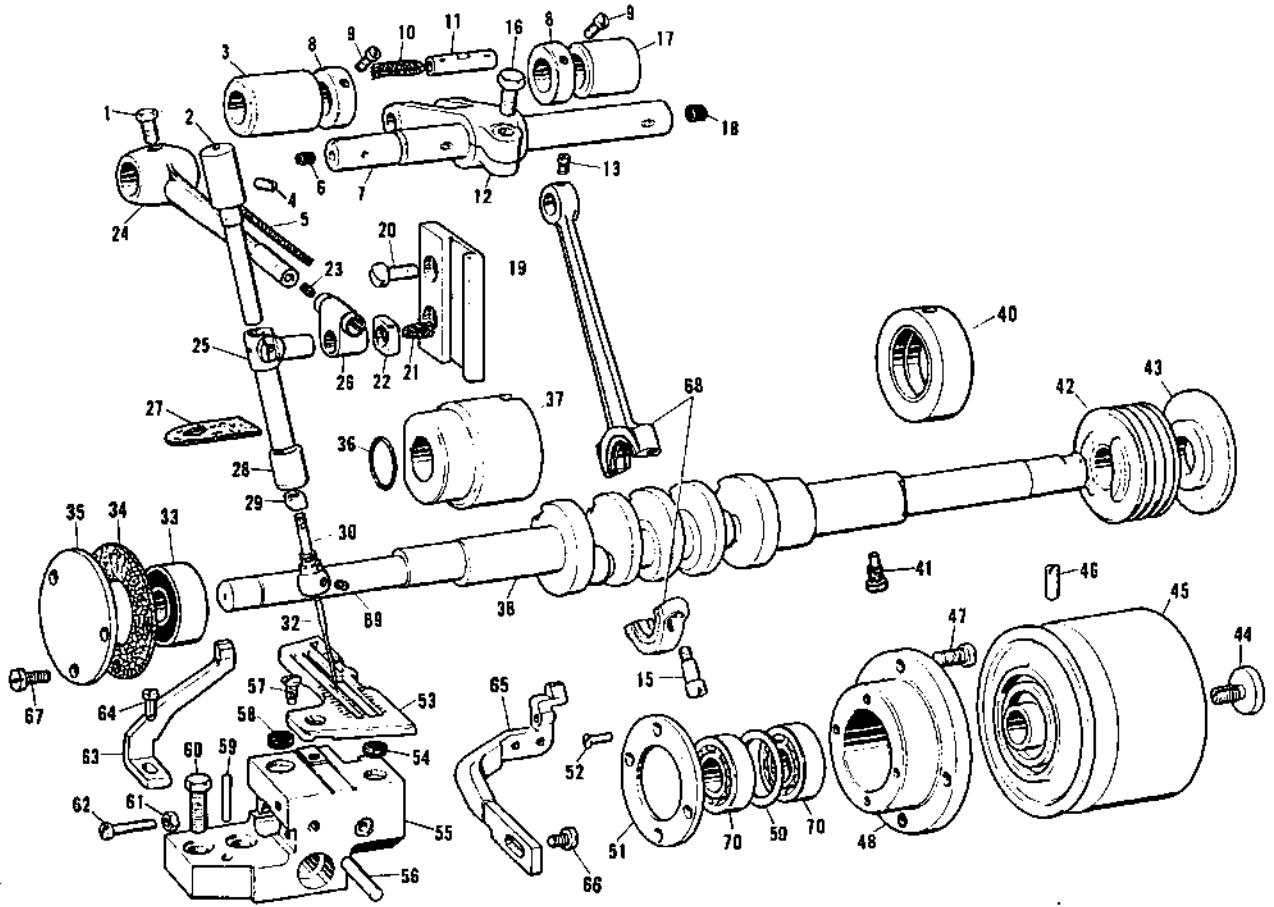

| Ref. No. | Name of Parts | Qty | Parts No. | Assembly No. | Ref. No. | Name of Parts | Qty | Parts No. | Assembly No. |
|----------|-----------------------------------|--------|-------------|--------------|----------|----------------------------------|--------|-------------|--------------|
| B-1 | Set Screw for B-24 | 1 pcc. | 140095-0-01 | | B-37 | Crank Shaft Bushing (Left) | 1 pcc. | 143174-0-00 | |
| B-2 | Needle Bar Bushing (Upper) | 1 - | 140097-0-01 | | B-38 | Crank Shaft | 1 - | 143183-0-01 | |
| B-3 | Needle Shaft Bushing (Left) | 1 - | 140093-0-00 | | B-40 | Crank Shaft Bushing (Centre) | 1 - | 143179-0-00 | |
| B-4 | Set Screw for B-2 | 1 - | 100260-0-01 | | B-41 | Screw for B-40 | 1 - | 110668-0-01 | |
| B-5 | Wick 6x6 (56) | 1 - | 140418-0-00 | | B-42 | Worm | 1 - | 140300-0-01 | |
| B-6 | Oil Cap 3.34x5 | 1 - | 140328-0-01 | | B-43 | Oil Rejector | 1 - | 140684-0-00 | |
| B-7 | Needle Shaft | 1 - | 140090-0-01 | | B-44 | Cap Screw for B-45 | 1 - | 140180-0-01 | |
| B-8 | Set Collar for B-7 | 2 pcs | 140092-0-01 | | B-45 | Pulley | 1 - | 140085-0-02 | |
| B-9 | Set Screw for B-8 | 4 - | 100366-0-01 | | B-46 | Set Screw for B-45 | 2 pcs. | 100016-0-03 | |
| B-10 | Wick 6x6 (52) | 1 pcc. | 140320-0-00 | | B-47 | Set Screw for B-48 | 4 - | 100368-0-02 | |
| B-11 | Pin for B-12 | 1 - | 140088-0-01 | | B-48 | Bearing Case | 1 pcc. | 110670-0-00 | |
| B-12 | Needle Arm Driving Lever | 1 - | 140089-0-01 | | B-50 | Thrust Washer | 1 - | 110672-0-00 | |
| B-13 | Set Screw for B-68 | 1 - | 100366-0-01 | 145638-0-01 | B-51 | Bearing Cover | 4 - | 110673-0-00 | |
| B-68 | Needle Arm Driving Crank Assembly | 1 - | 145639-0-01 | | B-52 | Set Screw for B-51 | 1 pcc. | 107244-0-01 | |
| B-15 | Set Screw for B-68 | 2 pcs. | 110686-0-01 | | B-53 | Needle Plate (K4) | 1 pcc. | 140445-0-01 | |
| B-16 | Hexagonal Bolt SM 6.35-40x16 | 1 pcc. | 017771-6-12 | | B-53 | Needle Plate (K3) | 1 - | 140444-0-01 | |
| B-17 | Needle Shaft Bushing (Right) | 1 - | 140091-0-00 | | B-53 | Needle Plate (K5) | 1 - | 140446-0-01 | |
| B-18 | Oil Cap 6.34x5 | 1 - | 140327-0-01 | | B-53 | Needle Plate (K511) | 1 - | 142346-0-01 | |
| B-19 | Needle Bar Guide | 1 - | 105079-0-01 | | B-54 | Cloth Plate Cushion (A) | 1 - | 140106-0-01 | |
| B-20 | Set Screw for B-19 | 2 pcs. | 100541-0-01 | | B-55 | Needle Plate Support Bracket | 1 - | 142294-0-02 | |
| B-21 | Wick 4x4 (30) | 2 - | 140415-0-00 | | B-56 | Dowel Pin | 1 - | 140063-0-01 | |
| B-22 | Slide Block for B-19 | 1 pcc. | 105078-0-01 | | B-57 | Set Screw for B-53 | 1 - | 100032-0-01 | |
| B-23 | Oil Cap 3.34x5 | 1 - | 140326-0-01 | | B-58 | Cloth Plate Cushion (B) | 1 - | 111486-0-01 | |
| B-24 | Needle Arm | 1 - | 140094-0-01 | | B-59 | Taper Pin 3.5x21 | 1 - | 107351-0-01 | |
| B-25 | Needle Bar | 1 - | 140098-0-04 | | B-60 | Hexagonal Bolt SM 6.35-28 x20 | 2 pcs. | 017782-0-14 | |
| B-26 | Needle Bar Connector | 1 - | 140096-0-01 | | B-61 | Nut for B-62 | 1 pcc. | 106129-0-01 | |
| B-27 | Felt for B-28 | 1 - | 140425-0-01 | | B-62 | Set Screw for B-55 | 1 - | 101553-0-01 | |
| B-28 | Needle Bar Bushing (Lower) | 1 - | 140099-0-00 | | B-63 | Overlock Stitch Needle Guard (A) | 1 - | 143753-0-01 | |
| B-29 | Nut for B-30 | 1 - | 140100-0-02 | | B-64 | Set Screw for B-63 | 1 - | 100137-0-02 | |
| B-30 | Needle Clamp | 1 - | 143761-0-01 | | B-65 | Overlock Stitch Needle Guard (B) | 1 - | 143752-0-01 | |
| B-32 | Needle DC x 1 | 1 - | 112297-0-11 | | B-66 | Set Screw for B-65 | 1 - | 100541-0-02 | |
| B-33 | Bearing 6000D | 1 - | 072800-0-30 | | B-67 | Set Screw for B-35 | 3 pcs. | 100264-0-04 | |
| B-34 | Packing for B-35 | 1 - | 143312-0-01 | | B-69 | Needle Set Screw for B-30 | 1 pcc. | 014660-3-22 | |
| B-35 | Bearing Plate | 1 - | 143311-0-01 | | B-70 | Bearing 6001 | 2 pcs. | 072600-1-00 | |
| B-36 | Packing | 1 - | 114294-0-01 | | | | | | |

C

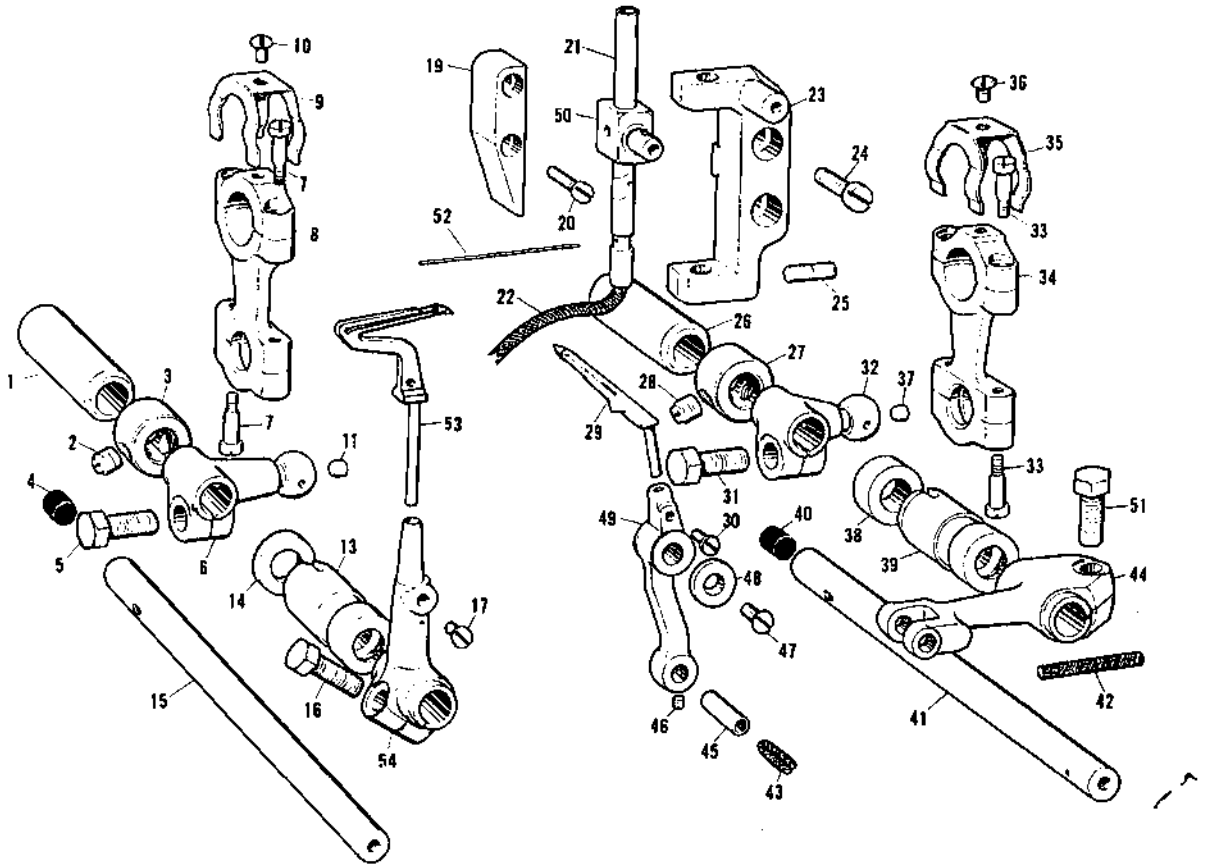

| Ref. No. | Name of Parts | Qty | Parts No. | Assembly No. | Ref. No. | Name of Parts | Qty | Parts No. | Assembly No. |
|----------|--------------------------------|--------|-------------|--------------|--------------------------------|--------------------|-------------|-------------|--------------|
| C-1 | Connecting Rod Bushing (Rear) | 1 pce. | 140116-0-00 | 180323-0-01 | C-29 | Over Looper | 1 pce. | 143733-0-01 | |
| C-2 | Set Screw for C-3 | 2 pcs. | 100289-0-01 | | C-30 | Set Screw for C-29 | 1 | 111473-0-01 | |
| C-3 | Set Collar | 1 pce. | 116778-0-01 | C-31 | Hexagonal Bolt SM 6.35-40x16 | 1 | 017773-6-12 | | |
| C-4 | Oil Cap 6.3x5 | 1 | 140327-0-01 | C-32 | Over Looper Supporter | 1 | 140113-0-01 | | |
| C-5 | Hexagonal Bolt SM 6.35-40x16 | 1 | 017771-6-12 | C-33 | Set Screw for C-34 | 3 pcs. | 142990-0-01 | 140111-0-01 | |
| C-6 | Under Looper Supporter | 1 | 140130-0-01 | C-34 | Looper Connecting Rod | 1 pce. | 140112-0-00 | | |
| C-7 | Set Screw for C-8 | 1 pce. | 142900-0-01 | C-35 | Looper Connecting Rod Stopper | 1 | 110704-0-01 | | |
| C-8 | Looper Connecting Rod | 1 pce. | 140112-0-00 | C-36 | Set Screw for C-35 | 1 | 105034-0-02 | | |
| C-9 | Looper Connecting Rod Stopper | 1 | 110704-0-01 | C-37 | Oil Cap 3.5x3 | 1 | 140709-0-00 | | |
| C-10 | Set Screw for C-9 | 1 | 105031-0-02 | C-38 | Thrust Collar for C-41 | 1 | 140117-0-01 | | |
| C-11 | Oil Cap 3.5x3 | 1 | 140709-0-00 | C-39 | Connecting Rod Bushing (Front) | 1 | 140118-0-00 | | |
| C-13 | Connecting Rod Bushing (Front) | 1 | 140118-0-00 | C-40 | Oil Cap 6.3x5 | 1 | 140327-0-01 | | |
| C-14 | Thrust Collar for C-15 | 1 | 110706-0-01 | C-41 | Shaft for C-32 | 1 | 140115-0-01 | | |
| C-15 | Shaft for C-6 | 1 | 143750-0-01 | C-42 | Wick 6x6 (27) | 1 | 140116-0-00 | | |
| C-16 | Hexagonal Bolt SM 5.56-32x14 | 1 | 017751-4-13 | C-43 | Wick 6x6 (32) | 1 | 140117-0-00 | | |
| C-17 | Set Screw for C-53 | 1 | 111443-0-01 | C-44 | Over Looper Driving Lever | 1 | 140119-0-01 | | |
| C-19 | Guide for C-22 | 1 | 140114-0-00 | C-45 | Pin for C-49 | 1 | 140120-0-01 | | |
| C-20 | Set Screw for C-19 | 2 pcs. | 105827-0-01 | C-46 | Set Screw for C-45 | 1 | 104651-0-05 | | |
| C-21 | Over Looper Holder Guide Shaft | 1 pce. | 140124-0-01 | C-47 | Flat Head Screw SM 3.57-40x6 | 1 | 003670-6-14 | | |
| C-22 | Wick 6x6 (90) | 1 | 140419-0-00 | C-48 | Washer for C-49 | 1 | 140127-0-01 | | |
| C-23 | Supporting Block for C-21 | 1 | 140125-0-01 | C-49 | Over Looper Holder | 1 | 140121-0-01 | | |
| C-24 | Set Screw SM 4.76-32x10 | 2 pcs. | 006711-0-13 | C-50 | Over Looper Holder Slide Block | 1 | 140122-0-01 | 140128-0-01 | |
| C-25 | Set Screw for C-21 | 1 pce. | 106069-0-01 | C-51 | Hexagonal Bolt SM 6.35-40x16 | 1 | 017771-6-12 | | |
| C-26 | Connecting Rod Bushing (Rear) | 1 | 140116-0-00 | C-52 | Long Pin 0.32x70 | 1 | 140774-0-00 | | |
| C-27 | Set Collar for C-26 | 1 | 116778-0-01 | C-53 | Under Looper | 1 | 143734-0-01 | | |
| C-28 | Set Screw for C-27 | 2 pcs. | 100289-0-03 | C-54 | Under Looper Holder | 1 | 143738-0-01 | | |

D

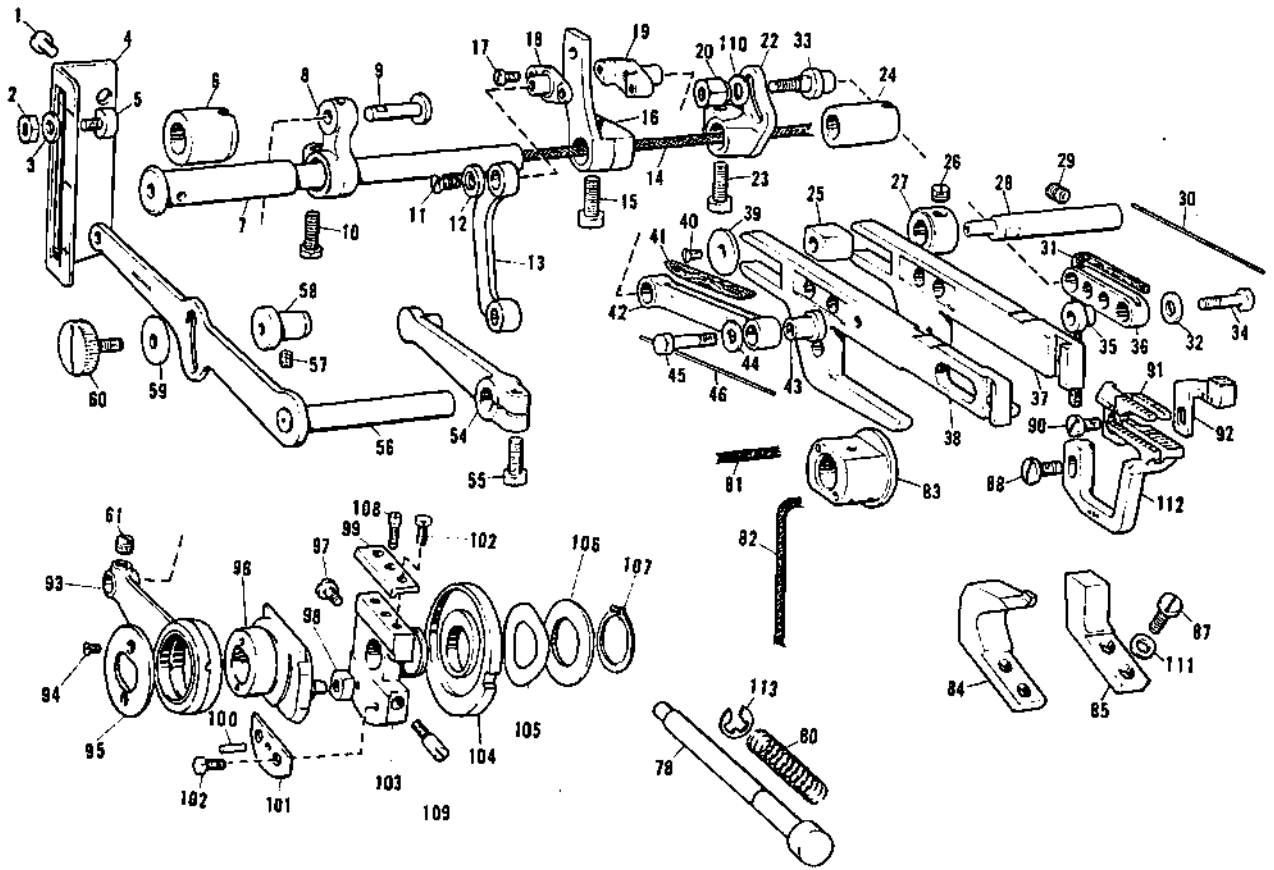

| Ref. No. | Name of Parts | Qty | Parts No. | Assembly No. | Ref. No. | Name of Parts | Qty | Parts No. | Assembly No. |
|----------|----------------------------------|--------|--------------|--------------|----------|-----------------------------------|--------|-------------|--------------|
| D-1 | Set Screw for D-1 | 2 pcs. | 100641-0-02 | | D-45 | Feed Link Shaft (Large) | 1 pce. | 140217-0-01 | |
| D-2 | Nut for D-5 | 2 | 110161-0-04 | | D-46 | Steel Wire 0.32x70 | 2 pcs. | 140774-0-00 | |
| D-3 | Washer for D-2 | 2 | 113431-0-02 | | D-54 | Differential Feed Link Lever | 1 pce. | 142588-0-01 | |
| D-4 | Differential Stitch Control | 1 pce. | 140228-0-01 | | D-55 | Hexagonal Bolt SM 6.35-40x14 | 1 | 017771-4-12 | |
| D-5 | Stopper Screw for D-1 | 2 pcs. | 140229-0-01 | | D-56 | Differential Feed Adjusting Lever | 1 | 144092-0-01 | |
| D-6 | Feed Shaft Bushing (Left) | 1 pce. | 140185-0-00 | | D-57 | Set Screw for D-58 | 1 | 100539-0-03 | |
| D-7 | Feed Shaft | 1 | 140-184-0-01 | | D-58 | Bushing for D-56 | 1 | 140226-0-01 | |
| D-8 | Feed Arm | 1 | 140179-0-01 | | D-59 | Washer for D-60 | 1 | 116662-0-01 | |
| D-9 | Pin for D-8 | 1 | 140-178-0-01 | | D-60 | Set Screw for D-56 | 1 | 143287-0-01 | |
| D-10 | Hexagonal Bolt SM 6.35-40x16 | 1 | 017771-6-12 | | D-61 | Set Screw for D-93 | 1 | 100251-0-01 | |
| D-11 | Set Screw for D-13 | 1 | 003670-6-14 | | D-78 | Feed Adjusting Shaft | 1 | 140182-0-01 | |
| D-12 | Washer for D-13 | 1 | 141188-0-01 | | D-80 | Feed Adjusting Spring | 1 | 140183-0-01 | |
| D-13 | Differential Feed Adjusting Link | 1 | 142589-0-01 | | D-81 | Wick 3x3 (20) | 1 pce. | 142673-0-00 | |
| D-14 | Wick 6x6 (135) | 1 | 140420-0-00 | | D-82 | Wick 3x3 (30) | 1 | 142674-0-00 | |
| D-15 | Hexagonal Bolt SM 6.35-40x14 | 1 | 017771-4-12 | | D-83 | Feed Lifting Slide Block | 1 | 140196-0-00 | |
| D-16 | Differential Feed Arm | 1 | 140212-0-01 | | D-84 | Feed Bar Guide (Left) | 1 | 142574-0-01 | |
| D-17 | Set Screw for D-18 | 2 pcs. | 109836-0-01 | 140211-0-01 | D-85 | Feed Bar Guide (Right) | 1 | 140197-0-01 | |
| D-18 | Cap for D-19 | 1 pce. | 140214-0-01 | | D-87 | Set Screw for D-84, D-85 | 4 pcs. | 107407-0-02 | |
| D-19 | Differential Feed Adjuster | 1 | 140213-0-01 | | D-88 | Set Screw for D-112 | 4 | 009681-2-12 | |
| D-20 | Nut for D-33 | 1 | 143565-0-01 | | D-90 | Set Screw for D-91 | 1 pce. | 140183-0-01 | |
| D-22 | Main Feed Arm | 1 | 140205-0-01 | | D-91 | Main Feed Dog | 1 | 140450-0-01 | |
| D-23 | Hexagonal Bolt SM 6.35-40x14 | 1 | 017771-4-12 | | D-92 | Chain Feed Dog | 1 | 142197-0-01 | |
| D-24 | Feed Shaft Bushing (Right) | 1 | 140186-0-00 | | D-93 | Feed Rod | 1 | 142260-0-01 | |
| D-25 | Feed Bar Guide Block | 1 | 140928-0-00 | | D-94 | Set Screw for D-95 | 2 pcs. | 111104-0-01 | |
| D-26 | Set Screw for D-27 | 2 pcs. | 101706-0-01 | | D-95 | Feed Rod Presser Plate | 1 pce. | 140176-0-01 | |
| D-27 | Set Collar for D-28 | 1 pce. | 104521-0-01 | 181955-0-01 | D-96 | Eccentric Wheel | 1 | 145266-0-01 | |
| D-28 | Main Feed Bar Guide Block Shaft | 1 | 140202-0-01 | | D-97 | Set Screw | 1 | 107093-0-02 | |
| D-29 | Set Screw for D-28 | 1 | 105183-0-01 | | D-98 | Slide Block for D-103 | 1 | 140165-0-01 | |
| D-30 | Steel Wire 0.32x70 | 2 pcs. | 140774-0-00 | | D-99 | Presser Plate (A) | 1 pce. | 145286-0-01 | |
| D-31 | Felt for D-36 | 1 pce. | 140771-0-01 | | D-100 | Taper Pin for D-101 | 1 | 100215-0-00 | |
| D-32 | Washer for D-33 | 1 | 140208-0-01 | | D-101 | Presser Plate (B) | 1 | 145289-0-01 | |
| D-33 | Main Feed Link Shaft (Large) | 1 | 143564-0-01 | | D-102 | Hexagonal Bolt SM 4.37-40x8 | 4 pcs. | 145290-0-01 | 145284-0-01 |
| D-34 | Main Feed Link Shaft (Small) | 1 | 140210-0-01 | | D-103 | Eccentric Wheel Holder | 1 | 145285-0-01 | |
| D-35 | Main Feed Link Bushing | 1 | 140207-0-01 | | D-104 | Eccentric Wheel Adjusting Cam | 1 | 144053-0-01 | |
| D-36 | Main Feed Link | 1 | 140209-0-01 | | D-105 | Ripple Type Spring | 1 | 144055-0-01 | |
| D-37 | Main Feed Bar | 1 | 140190-0-01 | 140189-0-01 | D-106 | Spring Presser Ring | 1 pce. | 144056-0-01 | |
| D-38 | Differential Feed Bar | 1 | 140191-0-01 | | D-107 | Stop Ring | 1 | 048150-1-43 | |
| D-39 | Slide Plate for D-25 | 1 | 140203-0-01 | | D-108 | Set Screw for D-103 | 2 pcs. | 100025-0-01 | |
| D-40 | Round Head Screw SM 3.18-40x7 | 1 | 005660-7-13 | | D-109 | Stopper Screw | 1 | 145663-0-01 | |
| D-41 | Felt for D-42 | 1 | 140772-0-01 | | D-110 | Washer for D-20 | 1 | 113431-0-02 | |
| D-42 | Differential Feed Link | 1 | 140215-0-01 | | D-111 | Washer for D-87 | 1 | 110735-0-01 | |
| D-43 | Differential Feed Link Bushing | 1 | 140216-0-01 | | D-112 | Differential Feed Dog | 1 | 140453-0-01 | |
| D-44 | Washer for D-42 | 1 | 140208-0-01 | | D-113 | Stop Ring | 1 | 048050-3-42 | |

E

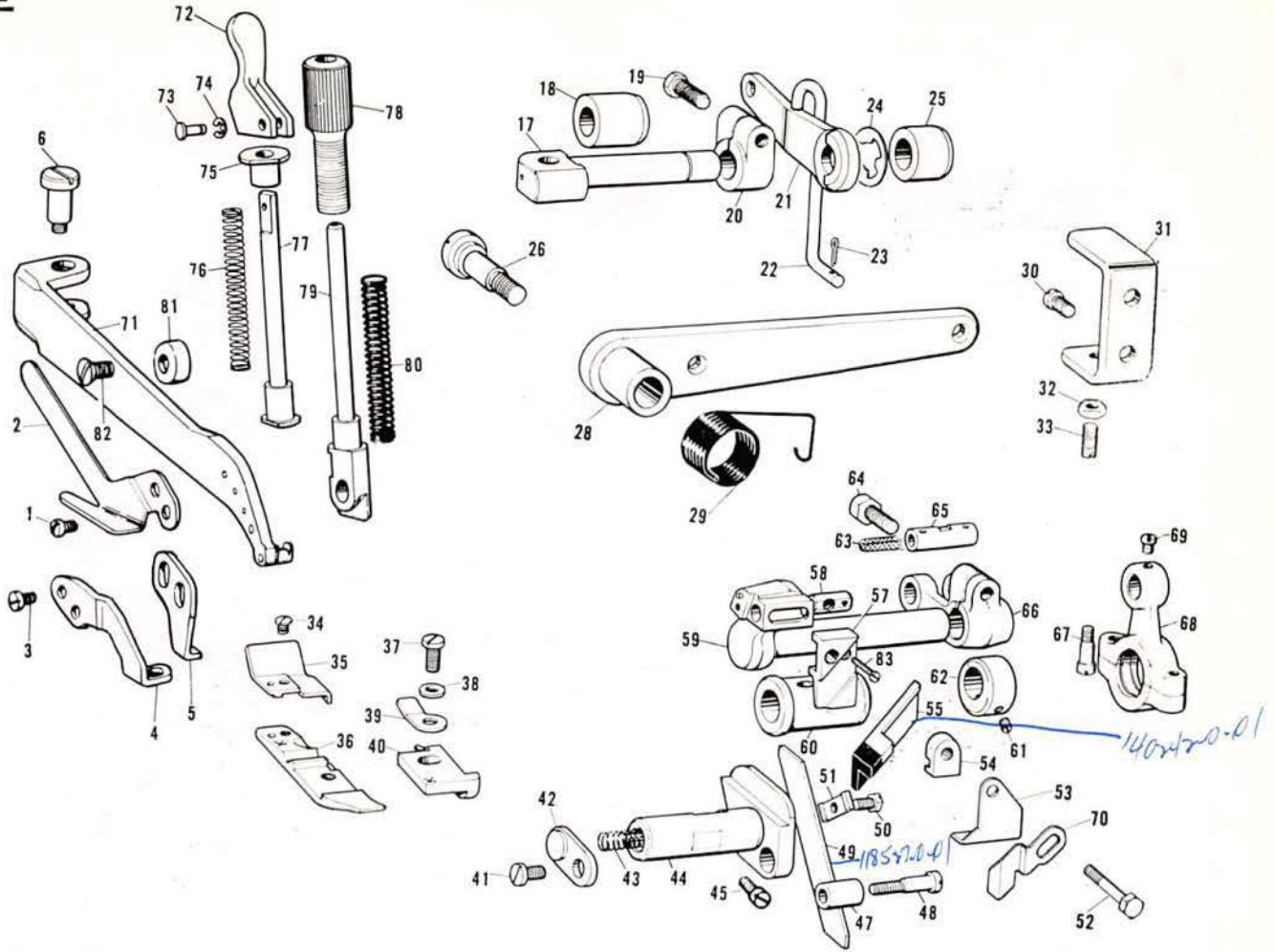

| Ref. No. | Name of Parts | Q'ty | Parts No. | Assembly No. | Ref. No. | Name of Parts | Q'ty | Parts No. | Assembly No. |
|----------|-----------------------------------|--------|-------------|--------------|----------|------------------------------|--------|-------------|--------------|
| E-1 | Set Screw for E-2 | 2 pcs. | 120048-0-02 | | E-48 | Set Screw for E-47 | 1 pce. | 104215-0-01 | |
| E-2 | Trimming Knife | 1 pce. | 140888-0-01 | | E-49 | Lower Knife | 1 * | 118527-0-01 | |
| E-3 | Set Screw for E-4 & E-5 | 2 pce. | 120048-0-02 | | E-50 | Set Screw for E-51 | 1 * | 117516-0-01 | |
| E-4 | Presser Foot Holder | 1 pce. | 113392-0-01 | | E-51 | Lower Knife Holding Plate | 1 * | 117515-0-01 | |
| E-5 | Presser Foot Stopper | 1 * | 140504-0-01 | | E-52 | Set Screw for E-57 | 1 * | 140457-0-01 | |
| E-6 | Stud Screw for E-71 | 1 * | 140267-0-01 | | E-53 | Upper Knife Clamp (B) | 1 * | 140241-0-01 | |
| E-17 | Presser Arm Shaft | 1 * | 140264-0-01 | | E-54 | Upper Knife Fastener | 1 * | 140240-0-01 | |
| E-18 | Bushing for E-17 | 1 * | 140263-0-00 | | E-55 | Upper Knife (B) | 1 * | 140242-0-01 | |
| E-19 | Hexagonal Bolt SM 6.35-40x16 | 1 * | 017771-6-12 | | E-57 | Upper Knife Holding Block | 1 * | 140455-0-01 | |
| E-20 | Set Collar for E-17 | 1 * | 140261-0-01 | | E-58 | Nut for E-57 | 1 * | 140238-0-01 | |
| E-21 | Presser Foot Lifter Lever | 1 * | 143327-0-01 | | E-59 | Upper Knife Driving Arm | 1 * | 143320-0-01 | |
| E-22 | Presser Foot Lifter Ring | 1 * | 143326-0-01 | | E-60 | Bushing for E-59 | 1 * | 140235-0-00 | |
| E-23 | Cotter Pin | 1 * | 110793-0-01 | | E-61 | Set Screw SM 5.56-32x6 | 2 pcs. | 013750-6-14 | |
| E-24 | Stop Ring | 1 * | 048080-3-42 | | E-62 | Set Collar for E-59 | 1 pce. | 140236-0-01 | |
| E-25 | Bushing (Right) for E-17 | 1 * | 140262-0-00 | | E-63 | Wick 6x6 (44) | 1 * | 140317-0-00 | |
| E-26 | Presser Foot Lifter Stud | 1 * | 143324-0-01 | | E-64 | Hexagonal Bolt SM 6.35-40x16 | 1 * | 017771-6-12 | |
| E-28 | Presser Foot Lifter Lever | 1 * | 143323-0-01 | | E-65 | Pin for E-69 | 1 * | 140232-0-01 | |
| E-29 | Spring for E-28 | 1 * | 143325-0-01 | | E-66 | Upper Knife Driving Lever | 1 * | 140233-0-01 | |
| E-30 | Set Screw for E-31 | 2 pcs. | 100541-0-02 | | E-67 | Set Screw for E-68 | 2 pcs. | 110686-0-01 | 140230-0-01 |
| E-31 | Adjuster for E-28 | 1 pce. | 140277-0-01 | | E-68 | Upper Knife Driving Rod | 1 pce. | 140231-0-00 | |
| E-32 | Nut for E-33 | 1 * | 110161-0-04 | | E-69 | Set Screw for E-68 | 1 * | 100366-0-01 | |
| E-33 | Stopper Screw for E-28 | 1 * | 106069-0-03 | | E-70 | Upper Knife Guard | 1 * | 143442-0-01 | |
| E-34 | Set Screw for E-35 | 1 * | 100105-0-02 | | E-71 | Main Presser Arm | 1 * | 144087-0-01 | |
| E-35 | Presser Foot Chain Shield (K) | 1 * | 140463-0-01 | | E-72 | Presser Bar Lifter | 1 * | 144082-0-01 | |
| E-36 | Presser Foot (K) | 1 * | 140461-0-01 | | E-73 | Pin for E-72 | 1 * | 144084-0-01 | |
| E-37 | Set Screw for E-39 | 1 * | 100080-0-02 | 140460-0-01 | E-74 | Stop Ring for E-73 | 1 * | 048020-3-42 | |
| E-38 | Washer for E-37 | 1 * | 110807-0-01 | | E-75 | Holder for E-72 | 1 * | 144083-0-01 | |
| E-39 | Presser Foot Hinge Spring | 1 * | 110806-0-01 | | E-76 | Spring for E-77 | 1 * | 144086-0-01 | |
| E-40 | Presser Foot Stitch Tongue (K) | 1 * | 140462-0-01 | | E-77 | Presser Bar Lifting Shaft | 1 * | 144085-0-01 | |
| E-41 | Set Screw for E-43 | 1 * | 100541-0-02 | | E-78 | Presser Foot Adjusting Screw | 1 * | 144079-0-01 | |
| E-42 | Lower Knife Holder Spring Stopper | 1 * | 140248-0-01 | | E-79 | Presser Bar | 1 * | 144080-0-01 | |
| E-43 | Lower Knife Holder Spring | 1 * | 140246-0-01 | | E-80 | Presser Bar Spring | 1 * | 144081-0-01 | |
| E-44 | Lower Knife Holder | 1 * | 140458-0-01 | | E-81 | Stopper for E-71 | 1 * | 144088-0-01 | |
| E-45 | Set Screw for E-44 | 1 * | 120823-0-01 | | E-82 | Set Screw for E-81 | 1 * | 107231-0-01 | |
| E-47 | Lower Knife Holder Guide | 1 * | 140247-0-01 | | E-83 | Set Screw for E-57 | 1 * | 009639-4-12 | |

F

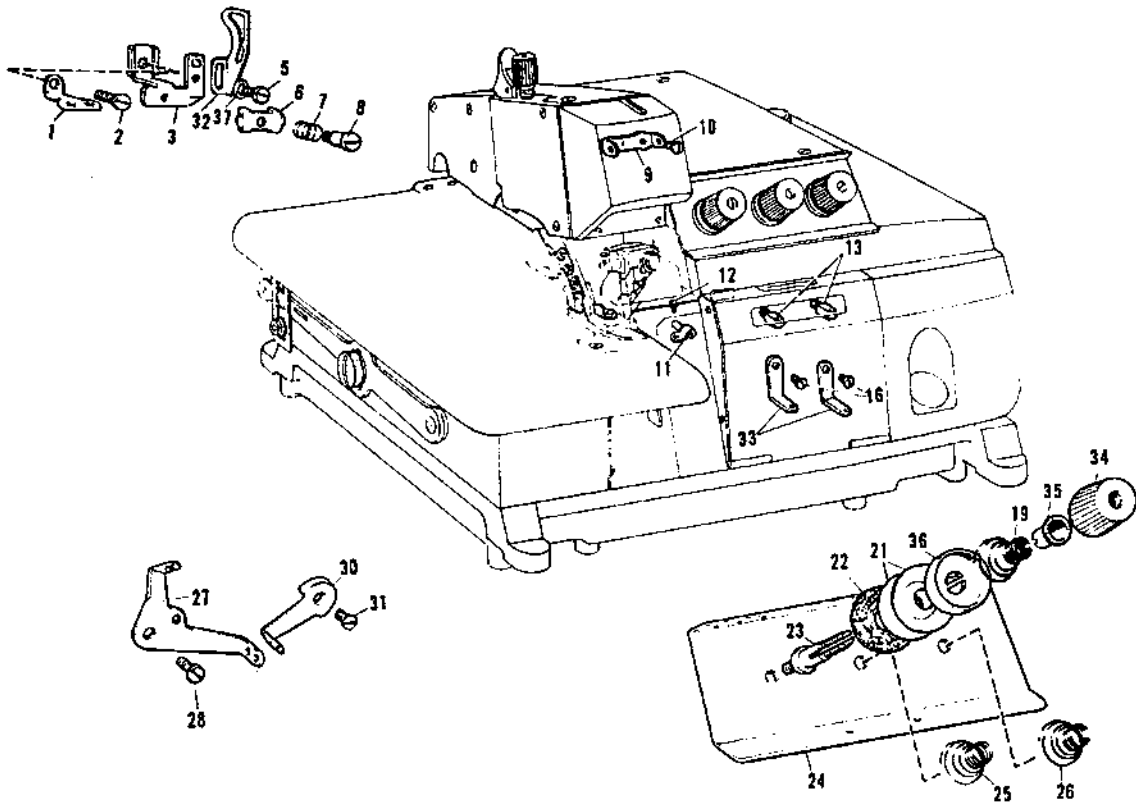

| Ref. No. | Name of Parts | Qty | Parts No. | Assembly Nu. | Ref. No. | Name of Parts | Qty | Parts No. | Assembly Nu. |
|----------|--|--------|-------------|--------------|----------|--|--------|-------------|--------------|
| F-1 | Needle Thread Guide (B) | 1 pce. | 140103-0-01 | | F-23 | Looper Thread Tension Control Stud | 3 pcs. | 110820-0-01 | |
| F-2 | Set Screw for F-1, 3 | 1 * | 100185-0-04 | | F-24 | Thread Guide Plate | 1 pce. | 140278-0-01 | |
| F-3 | Needle Thread Take-up Supporter | 1 * | 140102-0-01 | | F-25 | Over Looper Thread Tension Adjusting Spring | 1 * | 110821-0-01 | |
| F-5 | Set Screw for F-4 | 1 * | 009669-3-13 | | F-26 | Under Looper Thread Tension Adjusting Spring | 1 * | 110822-0-01 | |
| F-6 | Needle Thread Guard | 1 * | 112300-0-01 | | F-27 | Looper Thread Take-up (Left) | 1 * | 143768-0-01 | |
| F-7 | Needle Thread Guard Spring | 1 * | 112299-0-01 | | F-28 | Set Screw for F-27 | 1 * | 105123-0-01 | |
| F-8 | Stud Screw for F-6 | 1 * | 112301-0-01 | | F-30 | Looper Thread Take-up (Right) | 1 * | 140286-0-01 | |
| F-9 | Needle Thread Guide (A) | 1 * | 143757-0-01 | | F-31 | Flat Head Screw SM 3.57-40x6 | 1 * | 003670-0-14 | |
| F-10 | Set Screw for F-9 | 1 * | 403865-0-02 | | F-32 | Needle Thread Take-up | 1 * | 144108-0-01 | |
| F-11 | Over Looper Thread Guide (B) | 1 * | 142669-0-01 | | F-33 | Looper Thread Guide (A) | 2 pcs. | 144112-0-01 | |
| F-12 | Set Screw for F-11 | 1 * | 100035-0-01 | | F-34 | Thread Tension Adjusting Screw | 3 * | 144106-0-01 | |
| F-13 | Looper Thread Guide | 2 pcs. | 140281-0-01 | | F-35 | Tension Spring Washer | 3 * | 144105-0-00 | |
| F-16 | Set Screw for F-33 | 2 * | 100185-0-04 | | F-36 | Tension Disc Washer | 3 * | 144104-0-01 | |
| F-19 | Needle Thread Tension Adjusting Spring | 1 pce. | 110815-0-01 | | F-37 | Washer for F-32 | 1 pce. | 105218-0-01 | |
| F-21 | Tension Disc | 6 pcs. | 108721-0-01 | | | | | | |
| F-22 | Felt for F-21 | 3 * | 110832-0-01 | | | | | | |

G

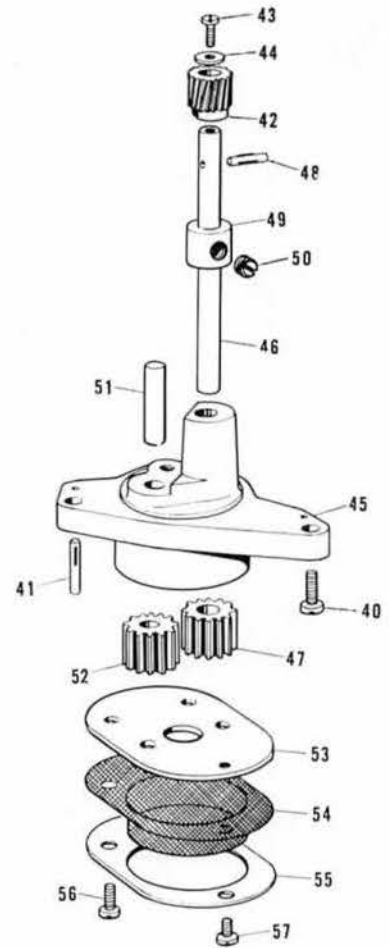
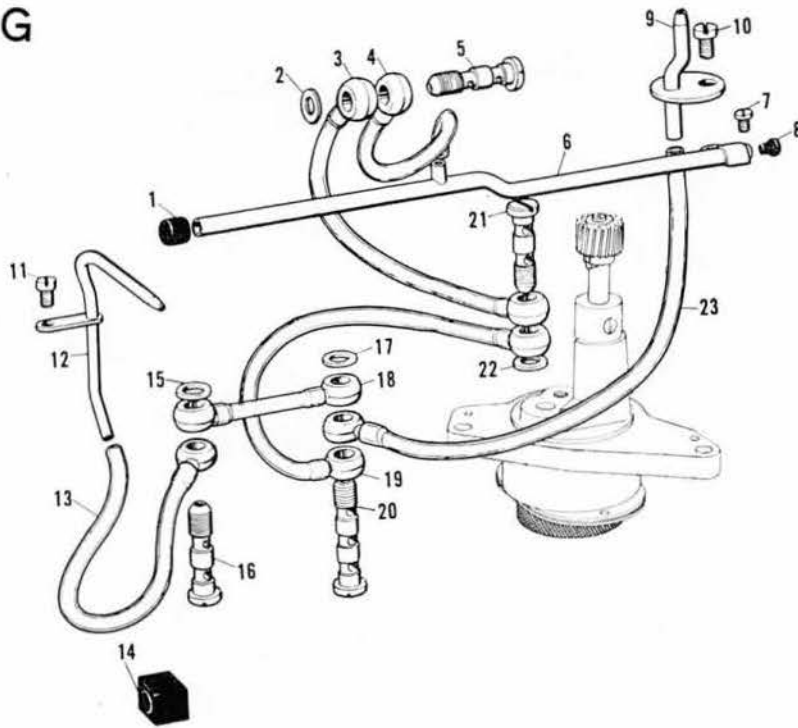

| Ref. No. | Name of Parts | Qty | Parts No. | Assembly No. | Ref. No. | Name of Parts | Qty | Parts No. | Assembly No. |
|----------|-------------------------|--------|-------------|--------------|----------|-------------------------|--------|-------------|--------------|
| G-1 | Oil Cap | 1 pce. | 140325-0-01 | | G-22 | Packing for G-21 | 1 * | 112348-0-01 | |
| G-2 | Packing for G-5 | 1 * | 112348-0-01 | | G-23 | Vinyl Tube (C) 6φ × 230 | 1 * | 140782-0-01 | |
| G-3 | Vinyl Tube (A) 6φ × 230 | 1 * | 140780-0-01 | | G-40 | Set Screw for G-45 | 2 * | 105173-0-03 | |
| G-4 | Vinyl Tube (B) 6φ × 180 | 1 * | 140781-0-01 | | G-41 | Pin 3×16 for G-45 | 2 * | 508693-0-01 | |
| G-5 | Oil Feeding Pipe (B) | 1 * | 112364-0-01 | | G-42 | Worm Wheel | 1 * | 144619-0-00 | |
| G-6 | Main Oil Pipe | 1 * | 143534-0-01 | | G-43 | Set Screw for G-42 | 1 pce. | 100137-0-01 | |
| G-7 | Set Screw for G-6 | 2 pcs. | 100185-0-03 | | G-44 | Washer for G-42 | 1 * | 025350-3-32 | |
| G-8 | Oil Cap | 1 pce. | 104833-0-01 | | G-45 | Pump Case | 1 * | 144618-0-00 | |
| G-9 | Pilot Pipe | 1 * | 140314-0-01 | | G-46 | Main Pump Gear Shaft | 1 * | 144620-0-01 | |
| G-10 | Set Screw for G-9 | 1 * | 100541-0-01 | | G-47 | Main Pump Gear | 1 * | 140305-0-01 | |
| G-11 | Set Screw G-12 | 1 * | 100185-0-03 | | G-48 | Dowel Pin | 1 * | 144622-0-01 | |
| G-12 | Oil Pipe for Feed Rod | 1 * | 140764-0-01 | | G-49 | Set Collar for G-46 | 1 * | 104527-0-01 | |
| G-13 | Vinyl Tube (B) 6φ × 180 | 1 * | 140782-0-01 | | G-50 | Set Screw for G-49 | 2 pcs. | 101706-0-01 | 144617-0-01 |
| G-14 | Tube Holder for G-13 | 1 * | 140768-0-01 | | G-51 | Subordinate Pump Shaft | 1 * | 144621-0-01 | |
| G-15 | Packing for G-16 | 1 * | 112348-0-01 | | G-52 | Subordinate Pump Gear | 1 * | 140468-0-01 | |
| G-16 | Oil Feeding Pipe (B) | 1 * | 112364-0-01 | | G-53 | Pump Cover | 1 * | 144623-0-00 | |
| G-17 | Packing for G-20 | 1 * | 112348-0-01 | | G-54 | Oil Filter Gauze | 1 * | 144624-0-00 | |
| G-18 | Vinyl Tube (D) 6φ × 50 | 1 * | 140778-0-01 | | G-55 | Oil Filter Flange | 1 * | 144625-0-00 | |
| G-19 | Vinyl Tube (A) 6φ × 230 | 1 * | 140780-0-01 | | G-56 | Set Screw for G-53 | 4 pcs. | 000680-8-12 | |
| G-20 | Oil Feeding Pipe (A) | 1 * | 112351-0-01 | | G-57 | Set Screw for G-55 | 1 pce. | 009689-4-12 | |
| G-21 | Oil Feeding Pipe (B) | 1 * | 112364-0-01 | | | | | | |

H

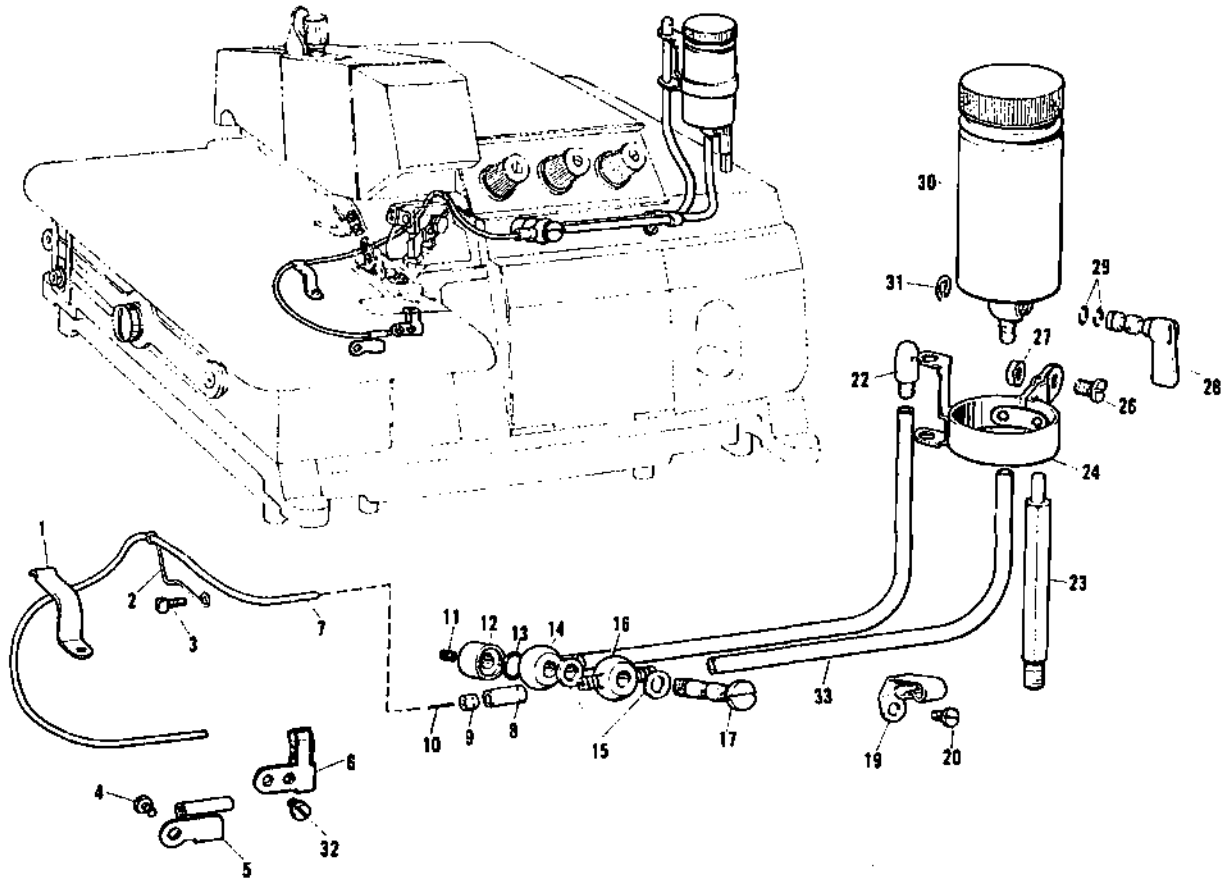

| Ref. No. | Name of Parts | Qty | Parts No. | Assembly No. | Ref. No. | Name of Parts | Qty | Parts No. | Assembly No. |
|----------|------------------------------|--------|-------------|--------------|----------|--------------------------------|--------|-------------|--------------|
| H-1 | Vinyl Tube Stopper | 1 pce. | 142286-0-01 | | H-16 | Oil Feeding Connector (Double) | 1 pce. | 142281-0-01 | |
| H-2 | Vinyl Tube Holder | 1 " | 142285-0-01 | | H-17 | Oil Feeding Connector | 1 " | 142282-0-01 | |
| H-3 | Set Screw SM 3.18-40x6 | 1 " | 009660-6-14 | | H-19 | Vinyl Tube Holder | 1 " | 142284-0-01 | |
| H-4 | Set Screw for Felt Holder | 1 " | 100185-0-04 | | H-20 | Screw for H-19 | 1 " | 100185-0-04 | |
| H-5 | Tube Guide | 1 " | 143760-0-01 | | H-22 | Air Vent Receptacle | 1 " | 142321-0-01 | |
| H-6 | Felt Holder | 1 " | 143912-0-01 | | H-23 | Oil Tank Holding Bolt | 1 " | 142316-0-01 | |
| H-7 | Vinyl Tube 0.5φ | 1 " | | | H-24 | Oil Tank Holder | 1 " | 142787-0-01 | |
| H-8 | Vinyl Tube 6φ x13 | 1 " | 142287-0-01 | 146195-0-01 | H-26 | Set Screw for H-24 | 2 pcs. | 110191-0-01 | 146195-0-01 |
| H-9 | Connector Tip | 1 " | | | H-27 | Nut for H-26 | 2 " | 110161-0-03 | |
| H-10 | Cooler Oil Adjusting Pin | 1 " | 142112-0-00 | | H-28 | Oil Cock | 1 pce. | 142330-0-01 | |
| H-11 | Cap for H-12 | 1 " | 140326-0-01 | | H-29 | Packing for H-28 | 2 pcs. | 081004-0-70 | |
| H-12 | Oil Feeding Connector Collar | 1 " | 142282-0-01 | | H-30 | Oil Tank | 1 pce. | 142229-0-01 | |
| H-13 | Packing for H-14 | 1 " | 104564-0-01 | | H-31 | Stop Ring for H-28 | 1 " | 048050-3-42 | |
| H-14 | Vinyl Tube 6φ x180 | 1 " | 142317-0-01 | | H-32 | Set Screw for H-6 | 2 pcs. | 100035-0-01 | |
| H-15 | Packing for H-16 | 2 pcs. | 112348-0-01 | | H-33 | Vinyl Tube 6φ x180 | 1 pce. | 141657-0-00 | |

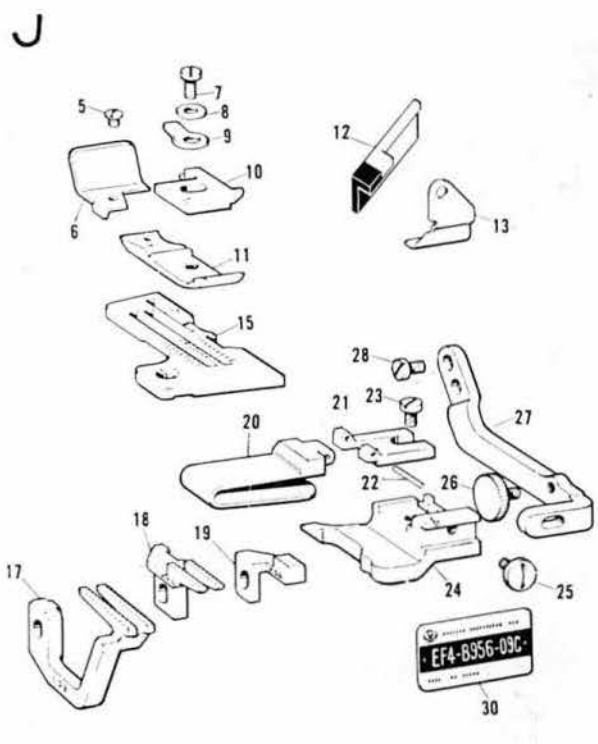
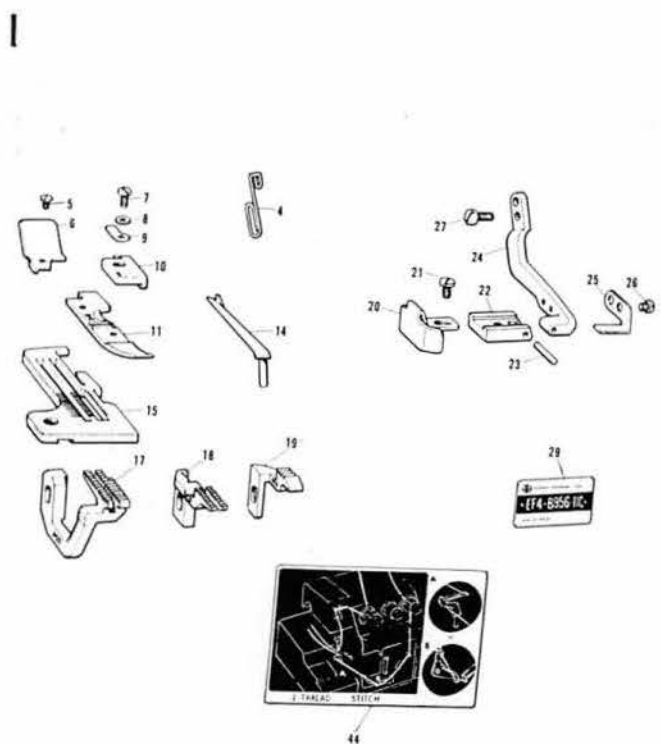

PARTS LIST for EF4-B956-11C(TWO THREADS)

PARTS LIST for EF4-B956-09C

This chart shows the different parts from Model EF-4-B956-01C
Other parts are same as EF-4-B956-01C

| Ref. No. | Name of Parts | Q'ty | Parts No. | Assembly No. |
|----------|---|--------|-------------|--------------|
| 1-4 | Needle Thread Take-up (for Two Threads) | 1 pce. | 142201-0-01 | |
| 1-5 | Set Screw for 1-6 | 1 * | 100105-0-02 | |
| 1-6 | Presser Foot (Rear) | 1 * | 142762-0-01 | |
| 1-7 | Set Screw for 1-9 | 1 * | 100080-0-02 | |
| 1-8 | Washer for 1-9 | 1 * | 110807-0-01 | 143153-0-01 |
| 1-9 | Presser Foot Hinge Spring | 1 * | 110806-0-01 | |
| 1-10 | Stitch Tongue | 1 * | 143155-0-01 | |
| 1-11 | Presser Foot (Front) | 1 * | 143154-0-01 | |
| 1-12 | Upper Knife (B) | 1 * | 140242-0-01 | |
| 1-13 | Upper Knife Clamp (B) | 1 * | 140241-0-01 | |
| 1-14 | Spreader for Two Threads | 1 * | 143151-0-01 | |
| 1-15 | Needle Plate (M5) | 1 * | 143150-0-01 | |
| 1-18 | Main Feed Dog (M5) | 1 * | 140451-0-01 | |
| 1-19 | Chin Feed Dog (M5) | 1 * | 143152-0-01 | |
| 1-20 | Edge Hemming Ruler | 1 * | 143157-0-01 | |
| 1-21 | Set Screw for K-20 | 1 * | 107491-0-02 | |
| 1-22 | Edge Hemming Ruler Set Plate | 1 * | | |
| 1-23 | Pin for K-22 | 1 * | 143158-0-01 | 143156-0-01 |
| 1-24 | Edge Hemming Ruler Bracket | 1 * | | |
| 1-25 | Base Plate for K-20 | 1 * | 143160-0-01 | |
| 1-26 | Set Screw for K-25 | 2 pcs. | 106568-0-01 | |
| 1-27 | Set Screw for K-24 | 2 * | 101629-0-02 | |
| 1-29 | Model Plate (B956-11C) | 1 pce. | 143545-0-01 | |
| 1-44 | Thread Diagram for Two Threads | 1 * | 143785-0-01 | |

This chart shows the different parts from Model EF-B956-01C
Other parts are same as EF4-B956-01C

| Ref. No. | Name of Parts | Q'ty | Parts No. | Assembly No. |
|----------|-----------------------------------|--------|-------------|--------------|
| J-5 | Set Screw for J-6 | 1 pce. | 100105-0-02 | |
| J-6 | Presser Foot Chain Shield (L) | 1 * | 142762-0-01 | |
| J-7 | Set Screw for J-9 | 1 * | 100080-0-02 | |
| J-8 | Washer for J-7 | 1 * | 110807-0-01 | 142199-0-01 |
| J-9 | Presser Foot Hing Spring | 1 * | 114727-0-01 | |
| J-10 | Presser Foot Stitch Tongue (L) | 1 * | 142200-0-01 | |
| J-11 | Presser Foot (L) | 1 * | 142277-0-01 | |
| J-12 | Upper Knife (A) | 1 * | 142198-0-01 | |
| J-13 | Upper Knife Clamp (A) | 1 * | 140456-0-01 | |
| J-14 | Needle Plate (L3) | 1 * | 142191-0-01 | |
| J-15 | Needle Plate (L4) | 1 * | 142192-0-01 | |
| J-16 | Differential Feed Dog (L3,6) | 1 * | 142196-0-01 | |
| J-17 | Main Feed Dog (K3,6) | 1 * | 140450-0-01 | |
| J-18 | Chain Feed Dog (K3,6) | 1 * | 142197-0-01 | |
| J-19 | Edge Hemming Ruler (A) | 1 * | | |
| J-20 | Hinge for J-20 | 1 * | 143552-0-01 | |
| J-21 | Hinge Pin for J-21 | 1 * | | |
| J-22 | Set Screw for J-20, 21, 22 | 1 * | 105123-0-01 | |
| J-23 | Edge Hemming Ruler (B) | 1 * | 142185-0-01 | 142184-0-01 |
| J-24 | Set Screw for J-24 | 1 * | 114855-0-01 | |
| J-25 | Adjusting Screw for Ruler Set | 1 * | 112836-0-01 | |
| J-26 | Edge Hemming Ruler Fitting Holder | 1 * | 142186-0-01 | |
| J-28 | Set Screw for J-27 | 2 pcs. | 101629-0-02 | |
| J-30 | Model Plate (EF4-B956-09C) | 1 pce. | 143269-0-01 | |

Z

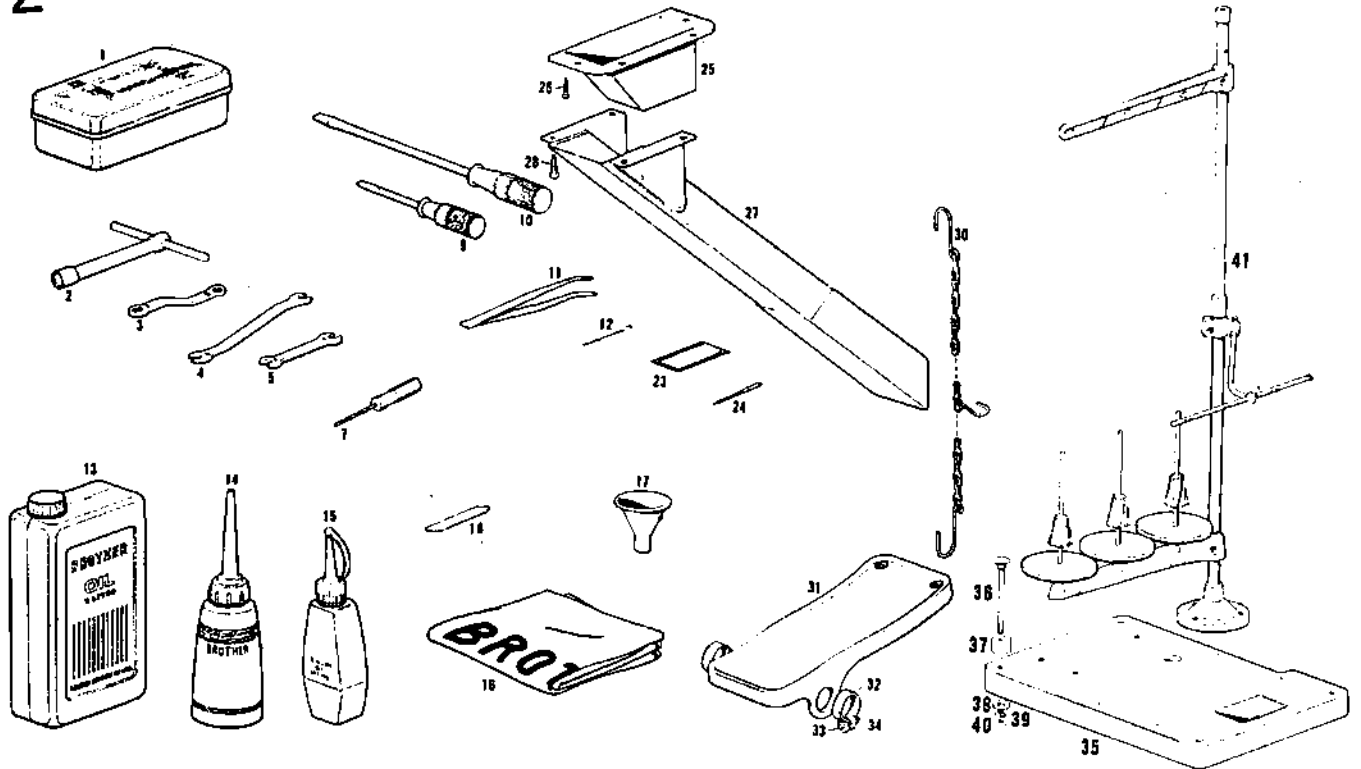

| Ref. No. | Name of Parts | Qty | Parts No. | Assembly No. | Ref. No. | Name of Parts | Qty | Parts No. | Assembly No. |
|----------|-------------------------|--------|-------------|--------------|----------|-------------------------------|---------|-------------|--------------|
| ● Z-1 | Accessory Box | 1 pce. | 110436-0-01 | | ● Z-23 | Needle Bag | 1 pce. | 108962-0-01 | |
| Z-2 | Box Wrench | 1 | 140342-0-01 | | ● Z-24 | Needle 10C×1 | 10 pcs. | 112297- | |
| ● Z-3 | Spanner 8×9 | 1 | 105343-0-01 | | Z-25 | Duster Drop | 1 pce. | 140798-0-01 | |
| ● Z-4 | Wrench 8×8 | 1 | 143566-0-01 | | Z-26 | Set Screw for Z-25 | 4 pcs. | 101795-0-01 | |
| ● Z-5 | Wrench 6×7 | 1 | 107779-0-01 | | Z-27 | Duster shoot | 1 pce. | 140792-0-01 | |
| ● Z-7 | Allen driver Wrench 1.5 | 1 | 144124-0-01 | | Z-28 | Set Screw for Z-27 | 4 pcs. | 031451-6-00 | |
| ● Z-9 | Screwdriver 5.5×75 | 1 | 102629-0-04 | | Z-30 | Chain (B) | 1 pce. | 106812-0-01 | |
| Z-10 | Screwdriver 5.5×200 | 1 | 101572-0-01 | | Z-31 | Foot Pedal | 1 | 117437-0-01 | |
| ● Z-11 | Tweezer | 1 | 117466-0-00 | | Z-32 | Foot Pedal Stopper | 2 pcs. | 116016-0-01 | |
| ● Z-12 | Thread Guide | 3 pcs. | 142125-0-00 | | Z-33 | Set Screw | 2 | 001401-4-06 | |
| Z-13 | Oil | 1 pce. | 145277-0-01 | | Z-34 | Nut | 2 | 021400-1-06 | |
| Z-14 | Oil | 1 | 114483-0-01 | | Z-35 | Wooden Plate for Machine head | 1 pce. | 142334-0-01 | |
| Z-15 | Needle Cooler Oil | 1 | 142343-0-01 | | Z-36 | Bolt | 4 pcs. | 140738-0-01 | |
| Z-16 | Head Cover | 1 | 144225-0-01 | | Z-37 | Collar | 4 | 140739-0-01 | |
| Z-17 | Funnel | 1 | 140739-0-00 | | Z-38 | Washer | 1 | 025080-3-36 | |
| ● Z-18 | Lower Knife | 1 | 118527-0-01 | | Z-39 | Spring Washer | 4 | 028080-2-43 | |
| | | | | | Z-40 | Nut | 4 | 021080-1-06 | |
| | | | | | Z-41 | Cotton Stand (No. 3 TII) | 1 pce. | 142977-0-01 | |

Remarks:

※The parts with mark (●) are in accessory box.

※The following parts are enclosed in the accessory box for our packing convenience.

Ref. No. A-18, A-19, A-52, A-53, A-82, A-87

MEMO

MEMO



118-956
192956-0-14
Printed in Japan